

## Lightning protection

### Protection of structures and open areas against lightning using early streamer emission air terminals.

French standard approved by AFNOR General Manager's decision dated June 5 1995 to become effective as from July 5 1995.

#### correspondence

No IEC publication or CENELEC harmonised document corresponds to this standard.

#### analysis

This standard describes the main measures for protecting buildings against direct lightning strokes using an early streamer emission lightning conductor. The principle of protecting buildings against lightning is based on the electro-geometrical model.

#### descriptors

Lightning, air-termination systems, down-conductors, earthing conductors, earth termination systems.

#### changes

#### corrections

## FOREWORD

This standard provides information for the state-of-the-art design of a satisfactory lightning protection system for structures (building, fixed facilities...) and open areas (storage areas, leisure or sports areas...) using an early streamer emission lightning conductor and provides instructions as to the methods to be used for achieving such protection.

As in the case with anything related to the natural elements, a lightning protection system, designed and installed in accordance with this standard, cannot guarantee absolute protection to structures, persons or objects; however, applying this standard will significantly reduce the risk of protected structures being damaged by lightning.

The decision to provide a structure with a lightning protection system depends on the following factors : lightning stroke probability, severity and acceptable consequences. The selection is based on the parameters contained in the risk assessment guide (Appendix B to this standard). The risk assessment guide also indicates the appropriate protection level.

Examples of structures which may need a lightning protection system are :

- buildings open to the public,
- tower blocks and, generally, high structures (pylons, water towers, lighthouses, etc.),
- buildings and warehouses containing dangerous materials (explosive, flammable or toxic materials, etc.),
- buildings containing highly vulnerable or valuable equipment or documents (such as telecommunication facilities, computers, archives, museums, historical monuments).

From the structure design stage onwards and then during the installation, particular attention should be paid to :

- take into consideration all the items which are to be used for making up a lightning protection system which meets the requirements of this standard by requesting professional advice from those involved in the sector : designers, builders, installers, users, etc.
- plan the complementary use of conductive items in the structures to be protected.

The measures stated in this standard are the minimum requirements for a statistically effective protection.

## Contents

1.	GENERAL .....	4
1.1	SCOPE AND OBJECT .....	4
1.2	REFERENCE STANDARDS .....	4
1.3	DEFINITIONS .....	5
1.4	STORMY PHENOMENA AND LIGHTNING PROTECTION SYSTEM BY E.S.E. LIGHTNING CONDUCTOR .....	7
2.	EXTERNAL LIGHTNING PROTECTION INSTALLATION (ELPI).....	10
2.1	GENERAL.....	10
2.2	AIR-TERMINATION SYSTEMS.....	11
2.3	DOWN-CONDUCTORS .....	19
3.	EQUIPOTENTIAL BONDING OF METAL PARTS AND INTERNAL LIGHTNING PROTECTION INSTALLATION .....	24
3.1	GENERAL.....	24
3.2	EQUIPOTENTIAL BONDING OF EXTERNAL METAL MASSES.....	26
3.3	EQUIPOTENTIAL BONDING OF METAL PARTS SUNK INTO WALLS.....	26
3.4	EQUIPOTENTIAL BONDING OF INTERNAL METAL PARTS : INTERNAL LIGHTNING PROTECTION INSTALLATION .....	27
4.	EARTH TERMINATION SYSTEMS .....	27
4.1	GENERAL.....	27
4.2	EARTH TERMINATION SYSTEM TYPES .....	28
4.3	ADDITIONAL MEASURES .....	30
4.4	EARTH TERMINATION SYSTEM INTERCONNECTION.....	30
4.5	PROXIMITY REQUIREMENTS.....	31
4.6	MATERIALS AND DIMENSIONS.....	31
5.	ANTICORROSION PROTECTION .....	32
5.1	GENERAL.....	32
5.2	PRECAUTIONS AND MEASURES TO BE TAKEN .....	32
6.	SPECIAL MEASURES.....	33
6.1	ANTENNAE.....	33
6.2	THATCHED ROOFS .....	34
6.3	FACTORY CHIMNEYS.....	34
6.4	FLAMMABLE AND EXPLOSIVE MATERIAL STORAGE AREAS .....	34
6.5	RELIGIOUS BUILDINGS.....	35
6.6	STRUCTURES OF ALTITUDE.....	36
6.7	OPEN AREAS, LEISURE OR SPORTS AREAS.....	36
6.8	TREES.....	36
7.	INSPECTION, MAINTENANCE .....	36
7.1	INITIAL INSPECTION.....	36
7.2	SCHEDULED INSPECTION.....	37
7.3	MAINTENANCE.....	38
	APPENDIX A .....	39
	APPENDIX B .....	43
	APPENDIX C .....	52
	APPENDIX D .....	57
	APPENDIX E .....	64

# 1. GENERAL

## 1.1 SCOPE AND OBJECT

### 1.1.1 Scope

This standard is applicable to the lightning protection using early streamer emission lightning conductors of common structures of less than 60-m high and of open areas (storage areas, leisure areas, etc.). It includes the protection against the electrical consequences due to the lightning current flow through the lightning protection system.

Notes :

1. This standard does not cover the protection of electrical equipment or systems against voltage surges of atmospheric origin which are transmitted by networks entering the structure.
2. Other standards describe lightning protection systems using simple rod lightning conductors, stretched wires and meshed conductors.  
Some Administrations, public services or operators of hazardous installations may have adopted specific regulations.

### 1.1.2 Scope

This standard provides the information for the design, construction, inspection and maintenance of lightning protection systems using early streamer emission lightning conductors. The purpose of these lightning protection systems is to safeguard persons and property as effectively as possible.

## 1.2 REFERENCE STANDARDS

The following standards contain provisions which are referred to herein and thus applicable to this standard. At the time of publishing, the stated issues were current. Any standard is subject to revision and the parties involved in agreements based on these standards are urged wherever possible to use the latest issues of the documents listed below :

NF C 15-100 (May 1991)  
Installations électriques à basse tension : Règles

NF C 90-120 (October 1983)  
Matériel électronique et de télécommunications - Antennes individuelles ou collectives de radiodiffusion sonore ou visuelle : Règles

NF C 17-100 (February 1987)  
Protection of structures against lightning - Requirements.

### 1.3 DEFINITIONS

#### 1.3.1 Lightning flash to earth

An electrical discharge of atmospheric origin between cloud and earth, consisting of one or more current impulses (return strokes).

#### 1.3.2 Lightning stroke

One or more lightning discharges to earth.

#### 1.3.3 Striking point

A point where a lightning stroke contacts the earth, a structure, or a lightning protection system.

#### 1.3.4 Protected volume

Volume of influence of the early streamer emission lightning conductor within which the early streamer emission lightning conductor is the striking point.

#### 1.3.5 Lightning flash density $N_g$

Yearly number of lightning flashes per  $\text{km}^2$ .

#### 1.3.6 Return stroke density $N_a$

Yearly number of return strokes per  $\text{km}^2$ . A lightning stroke consists, in average, of several return strokes. See map in Appendix B.

#### 1.3.7 Lightning protection system (LPS)

The complete system used to protect structures and open areas against the effects of lightning. It consists of an external lightning protection installation and of an internal lightning protection installation, if any.

#### 1.3.8 External lightning protection installation (ELPI)

An external lightning protection installation consists of an air-termination system, one or more down-conductors, and one or more earth termination systems.

#### 1.3.9 Internal lightning protection installation (ILPI)

An internal lightning protection installation consists of all the devices and measures reducing the electromagnetic effects of lightning current within the volume to be protected.

#### 1.3.10 Early streamer emission (E.S.E.) lightning conductor

A lightning rod equipped with a system which creates the triggering advance of the upward leader when compared with a simple rod (S.R.) lightning conductor in the same conditions.

#### **1.3.11 Triggering process**

Physical phenomenon between the inception of the first corona and the continuous propagation of an upward leader.

#### **1.3.12 Triggering advance ( $\Delta T$ )**

Mean gain in triggering time of the upward leader of the E.S.E. lightning conductor when compared with a S.R. lightning conductor in the same conditions and derived from the evaluation test. This is expressed in  $\mu s$ .

#### **1.3.13 Natural component**

A conductive part located outside the structure, sunk in the walls, or situated inside a structure and which may be used to replace all or part of a down-conductor or as a supplement to an ELPI.

#### **1.3.14 Equipotential bonding bar**

A collector used to connect the natural components, ground conductors, earth conductors, screens, shields and conductors protecting electrical telecommunication lines or other cables, to the lightning protection system.

#### **1.3.15 Equipotential bonding**

An electrical connection putting ground conductors and conductive parts at the same potential or a substantially equal potential.

#### **1.3.16 Equipotential conductor**

A conductor providing for equipotential bonding.

#### **1.3.17 Dangerous sparking**

An electric arc produced by a lightning current within the volume to be protected.

#### **1.3.18 Safety distance (S)**

The minimum distance for which no dangerous spark can be produced.

#### **1.3.19 Interconnected reinforcing steel**

Natural components within a structure which provide an electrical path resistance smaller than  $0.01 \Omega$  and can be used as down-conductors.

#### **1.3.20 Down-conductor**

Part of the external lightning protection installation designed to conduct the lightning current from the E.S.E. lightning conductor to the earth termination system.

### **1.3.21 Test joint/Disconnect terminal (or measurement terminal)**

A device used to disconnect the earth termination system from the remainder of the system.

### **1.3.22 Earth electrode**

A part or group of parts of the earth termination system which provides direct electrical contact with the earth and disperses the lightning current to earth.

### **1.3.23 Earth termination system**

A conductive part or a group of conductive parts in intimate contact with and providing an electrical connection with earth.

### **1.3.24 Earth termination system resistance**

Resistance between the test joint and earth : it equals the quotient of potential increase, measured at the test joint with respect to an infinitely remote reference, and of the applied current to the earth electrode.

### **1.3.25 Surge Protective Device (S.P.D.)**

A device designed to limit transient surge voltages and to provide a path for the current waves. It contains at least one non linear component.

### **1.3.26 Transient surge voltage of atmospheric origin**

Overtoltage lasting a few milliseconds only, oscillatory or not, usually strongly damped.

### **1.3.27 Protection level**

Classification of a lightning protection system which expresses its efficiency.

Note : This definition should not be confused with that used with surge protective device (S.P.D.).

### **1.3.28 Equivalent collection area of a structure $A_e$**

A flat ground surface subjected to the same number of lightning flashes as the structure under consideration.

## **1.4 STORMY PHENOMENA AND LIGHTNING PROTECTION SYSTEM BY E.S.E. LIGHTNING CONDUCTOR**

### **1.4.1 The storm phenomena and the need for lightning protection**

The need for protection is determined according to the lightning flash density of the area being considered. The probability of a structure being struck by lightning over a one-year period is the product of the lightning stroke frequency times its equivalent collection area.

The lightning flash density is given by the formula  $N_g = N_a/2.2$ ,  $N_a$  is given in the map situated in Appendix B.

The structure protection appropriateness and the protection level to be used are given in Appendix B.

Note : Other requirements (statutory requirements or personal considerations) may lead to the decision being taken to adopt protection measures for reasons other than statistical ones.

#### 1.4.2 Characteristic lightning parameters and associated effects

Lightning is mainly characterised by parameters related to the electric arc between the cloud and the ground, hence those related to the lightning current flow in the arc and the conductors.

The most important parameters are the following :

- amplitude,
- rise time,
- decay time,
- current variation rate ( $di/dt$ ),
- polarity,
- charge,
- specific energy,
- number of strikes per discharge.

The first three parameters are independent in terms of statistics. Any amplitude may be encountered, for instance, with any decay time (see the world-wide data presented in the tables in Appendix D).

As an electrical phenomenon, lightning may have the same consequences as any other current flowing through an electrical conductor or any other current flow through a bad conductor or an insulator.

The expected effects of the characteristic lightning parameters are as follows :

- optical effects,
- acoustical effects,
- electro-chemical effects,
- thermal effects,
- electro-dynamic effects,
- electro-magnetic radiation.

The thermal and electro-dynamic effects are taken into account when sizing the different components of the lightning protection system. The electro-magnetic radiation effects (flashover, inductions, etc.) are taken into consideration in article 3.

The remaining effects have no appreciable effect on the design of a lightning protection system. All the effects are described in Appendix D.

### 1.4.3 Components of a lightning protection system

A lightning protection system consists of an external lightning protection installation (ELPI) and, if necessary, of an additional internal lightning protection installation (ILPI).

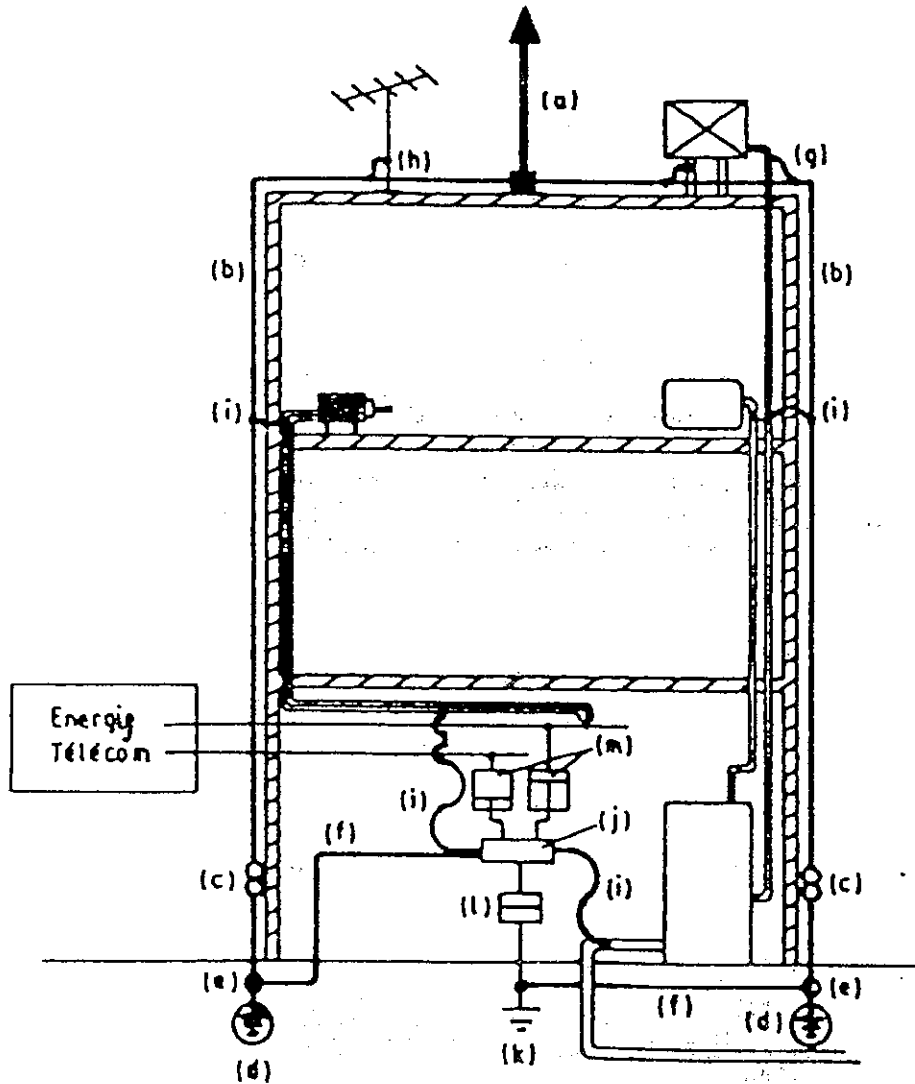

Figure 1.4.3

The external lightning protection installation consists of the following interconnected items :

- (a) One or more ESE lightning conductors
- (b) One or more down-conductors
- (c) A test joint for each down-conductor
- (d) A lightning conductor earth electrode for each down-conductor
- (e) Disconnectable connector
- (f) One or more connections between earths
- (g) One or more equipotential bonding
- (h) One or more equipotential bonding through antenna mast arrester

The internal lightning protection installation consists of :

- (i) One or more equipotential bonding(s)
- (j) One or more equipotential bonding bar(s)

The equipment of the electrical installation are :

- (k) Earth termination of the structure
- (l) Main earth terminal
- (m) One or more surge protective device(s).

## **2. EXTERNAL LIGHTNING PROTECTION INSTALLATION (ELPI)**

### **2.1 GENERAL**

#### **2.1.1 Design**

A prior survey should be conducted to determine the protection level to be considered, the E.S.E. lightning conductor location(s), the down-conductor path(s), the earth termination system location(s) and type(s).

Architectural constraints may be taken into account in the lightning protection system design but this may substantially reduce the lightning protection system effectiveness.

#### **2.1.2 Prior survey**

The prior survey is divided into two parts :

- (a) Assessment of the lightning strike probability and selecting the protection level using the data in Appendix B.
- (b) Location of all the elements of the lightning protection installation.

This information should take the form of a specification, stipulating :

- structure sizes,
- relative geographical position of the structure : isolated, on a hilltop, amidst other buildings which are higher, of the same height or lower,
- frequency with which the structure is occupied by people whose mobility is restricted or otherwise,
- risk of panic,
- difficulty of access,
- service continuity,

- structure contents : presence of persons, animals, flammable materials, sensitive equipment such as computers, electronic or high-value or irreplaceable apparatus,
- roof shapes and slopes,
- roof, wall and load-bearing structure types,
- metal parts of the roof and large external metal items, such as gas heaters, fans, stairs, antennae, water tanks,
- roof gutters and rainwater pipes,
- salient building parts and types of materials (metal or non-conductive material),
- most vulnerable points of the building,
- lay-out of the building metal pipes (water, electricity, gas, etc.),
- nearby obstacles which may affect the lightning path, such as overhead electrical lines, metal fences, trees, etc.,
- environmental conditions which may be highly corrosive (salt air, petrochemical plant, cement works, etc.).

The structural points considered as vulnerable are the salient parts, particularly towers or spires, chimney stacks and flues, roof gutters, edges, metal masses (air exhausters, main wall cleaning system, guardrails, etc.), staircases, equipment rooms on flat roofs.

## **2.2 AIR-TERMINATION SYSTEMS**

### **2.2.1 General principles**

An early streamer emission lightning conductor consists of a pointed air terminal, a triggering device and a support rod with a down-conductor connecting system.

The area protected by an E.S.E. lightning conductor can be determined using the electro-geometrical model, such as the one used in Appendix A, and the E.S.E. lightning conductor triggering advance as defined in 2.2.2.

The E.S.E. lightning conductor should preferably be installed on the highest point of the supporting structure. It should always be the highest point within the area that it protects.

### **2.2.2 Triggering advance**

An E.S.E. lightning conductor is characterised by its triggering advance which is demonstrated during evaluation tests. Such tests compare an early streamer emission lightning conductor against a simple rod lightning conductor situated in the same conditions.

The triggering advance ( $\Delta T$ ) is used for computing the protection radius. This is expressed as follows :

$\Delta T = T_{SR} - T_{E.S.E.}$  lightning conductor, where :

$T_{SR}$  is the mean triggering time of the upward leader of a simple rod lightning conductor.

$T_{E.S.E.}$  is the mean triggering time of the upward leader of a ESE lightning conductor.

### 2.2.2.1 E.S.E. lightning conductor evaluation test

This test procedure involves assessing the triggering advance of an E.S.E. lightning conductor. The natural conditions are simulated in the high-voltage laboratory by adding the superimposition of a permanent field, representative of the ambient field during a storm, and of an impulse field, representative of the downward leader approach.

Note : In-situ correlation tests are in the process of being defined.

### 2.2.3 Positioning of the E.S.E. lightning conductor

#### 2.2.3.1 Protected area

The protected area is delineated by the envelope of revolution having the same axis as the E.S.E. lightning conductor and defined by the protection radii corresponding the different heights  $h$  under consideration (see figure 2.2.3.1).

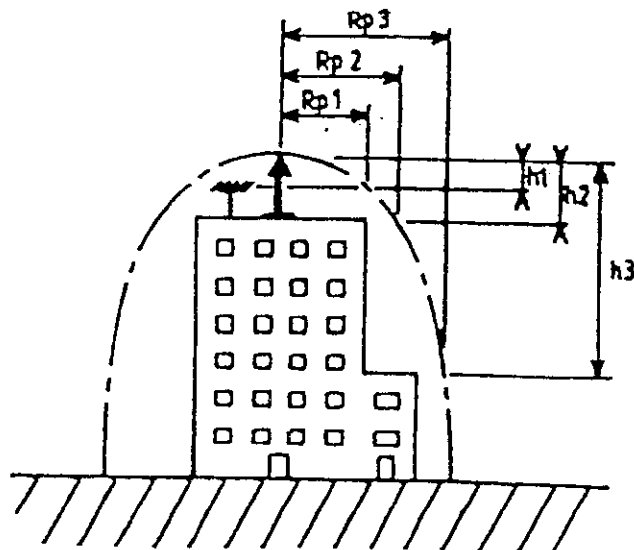

Figure 2.2.3.1. Protection radii

$h_n$  is the height of the E.S.E. lightning conductor tip relative to the horizontal plane passing through the top of the element to be protected.

$R_{Pn}$  is the E.S.E. lightning conductor protection radius at the height under consideration.

### 2.2.3.2 Protection radius

The protection radius of an E.S.E. lightning conductor is related to its height ( $h$ ) relative to the area to be protected, to its triggering advance and to the selected protection level. (See Appendix A.)

$$R_p = \sqrt{h(2D-h) + \Delta L(2D+\Delta L)} \quad \text{with } h \geq 5\text{m.} \quad (\text{Equation 1})$$

When  $h < 5\text{m}$ , the graphic method is applied using the curves in 2.2.3.3.a, b and c.

$R_p$  is the protection radius.

$h$  is the E.S.E. lightning conductor tip height relative to the horizontal plane passing through the top of the element to be protected.

$D$  is :

20m for protection level I,  
45m for protection level II,  
60m for protection level III.

$$\Delta L : \Delta L(\text{m}) = v(\text{m}/\mu\text{s}) \cdot \Delta T(\mu\text{s}), \quad \text{where : (Equation 2)}$$

$\Delta T$  is the triggering advance determined by the evaluation tests (see 2.2.2.1) as defined in Appendix C.

### 2.2.3.3 Selection and positioning of an E.S.E. lightning conductor.

A prior survey is conducted to determine the required protection level (see para. 2.1.2) for each lightning protection system installation.

The required protection radius  $R_p$  for the protection of the structure is then determined using equation 1 or the curves in figures 2.2.3.3.a, b, c for  $h \geq 5\text{m}$ , and using the curves in figures 2.2.3.3. a), b) or c) for  $h < 5\text{m}$  for protection levels I to III as follows :

- level I : graph of figure 2.2.3.3.(a)
- level II : graph of figure 2.2.3.3.(b)
- level III : graph of figure 2.2.3.3.(c)

When the graphs are used, the protection radius  $R_p$  is determined by locating required height  $h$  and  $\Delta L$  for the E.S.E. lightning conductor under consideration in the appropriate graph.

Note : The  $\Delta L$  values in the graphs are non-restrictive examples.

D = 20 m

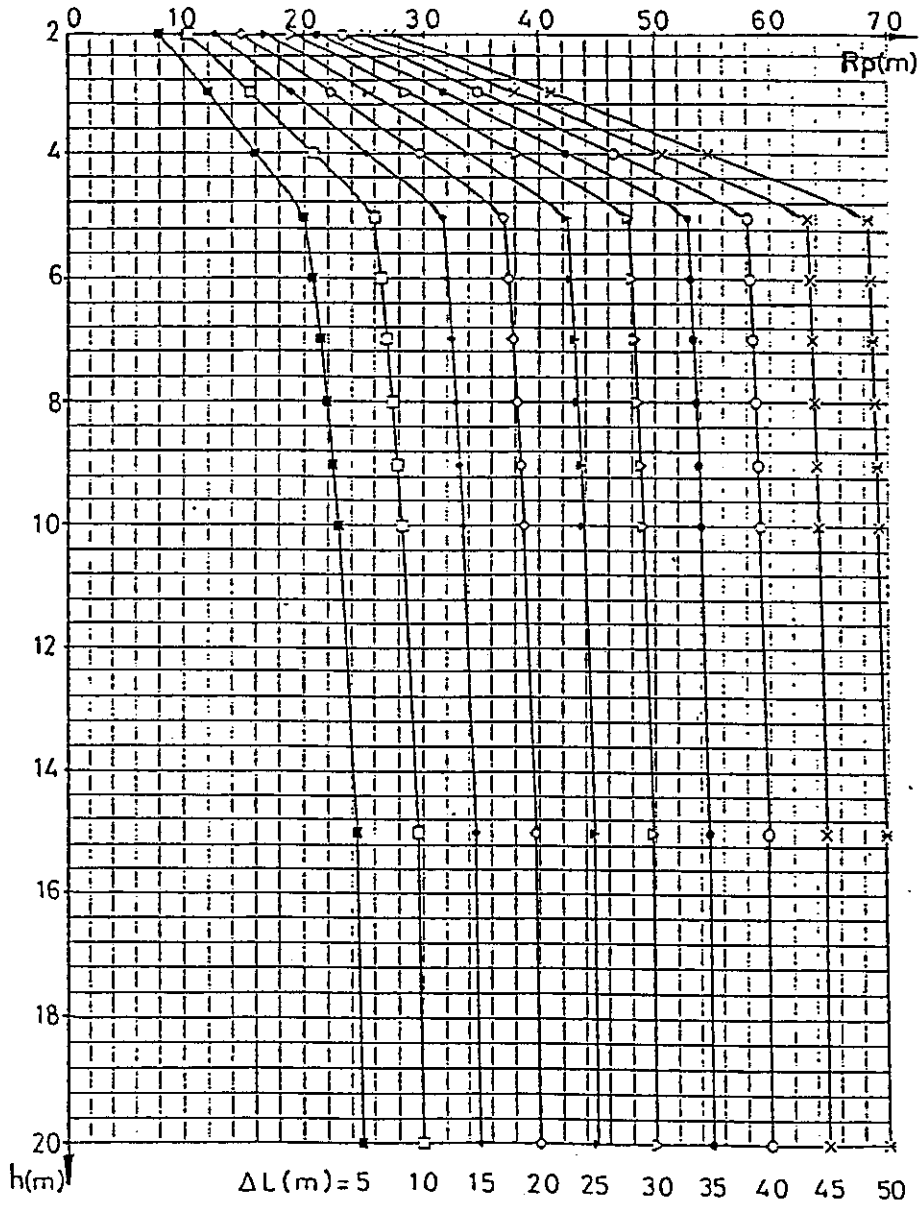

Radii of protection for h = 20 to 60 m

D (m)										
20										
ΔL (m)	5	10	15	20	25	30	35	40	45	50
h (m)	Rp (m)									
20	25.00	30.00	35.00	40.00	45.00	50.00	55.00	60.00	65.00	70.00
25	25.00	30.00	35.00	40.00	45.00	50.00	55.00	60.00	65.00	70.00
30	25.00	30.00	35.00	40.00	45.00	50.00	55.00	60.00	65.00	70.00
35	25.00	30.00	35.00	40.00	45.00	50.00	55.00	60.00	65.00	70.00
40	25.00	30.00	35.00	40.00	45.00	50.00	55.00	60.00	65.00	70.00
45	25.00	30.00	35.00	40.00	45.00	50.00	55.00	60.00	65.00	70.00
50	25.00	30.00	35.00	40.00	45.00	50.00	55.00	60.00	65.00	70.00
55	25.00	30.00	35.00	40.00	45.00	50.00	55.00	60.00	65.00	70.00
60	25.00	30.00	35.00	40.00	45.00	50.00	55.00	60.00	65.00	70.00

$D$  (m) is the striking distance or rolling sphere radius.

$\Delta L$ (m) is the triggering advance of the E.S.E. lightning conductor considered.

$h$ (m) is the height difference between the air terminal tip and the horizontal plane considered.

$R_p$ (m) is the protection radius in the horizontal plane considered.

Figure 2.2.3.3. (a)  
Radii of protection of the E.S.E. lightning conductors  
Level of protection I ( $D = 20$  m)

$D = 45$  m

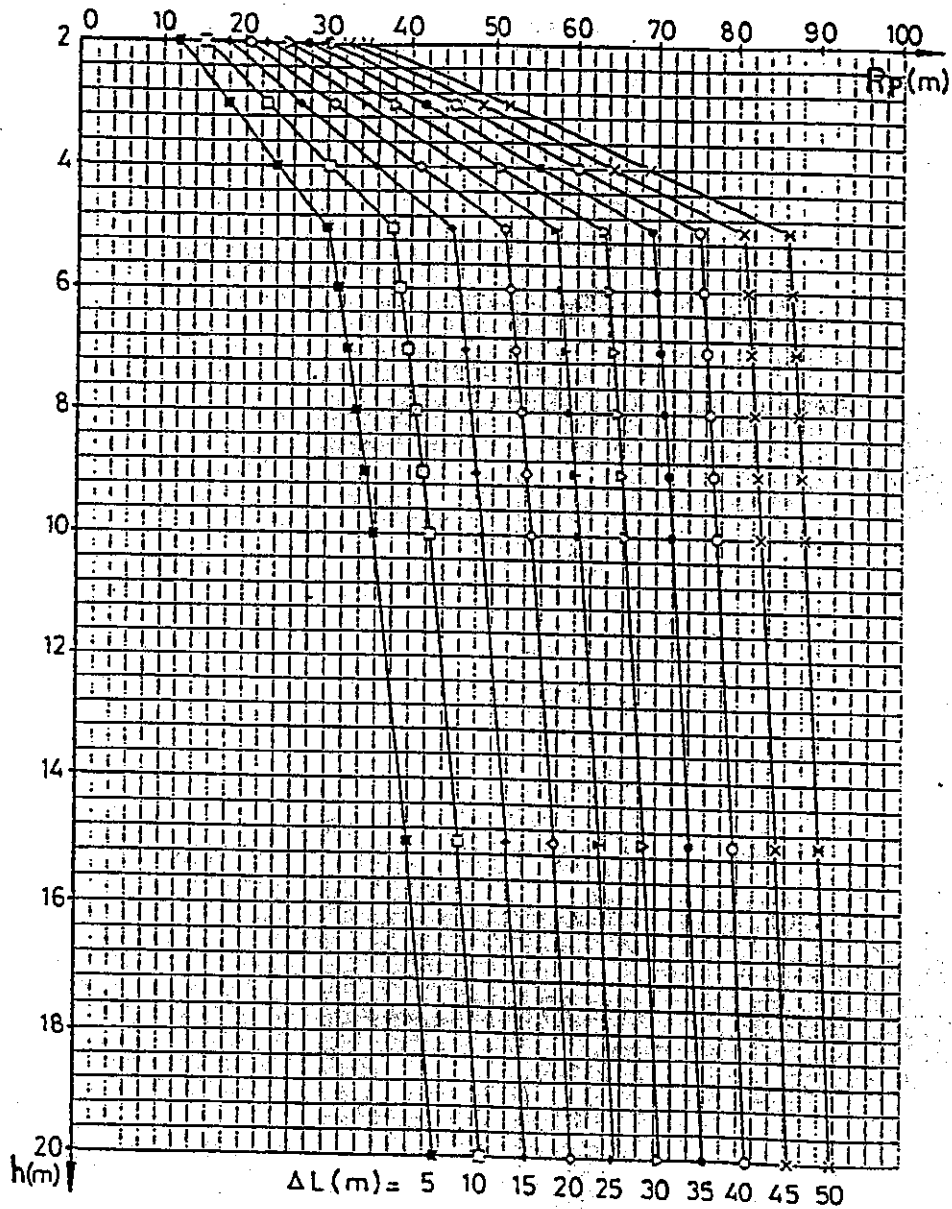

Radii of protection for h = 20 to 60m

D (m)										
45										
$\Delta L$ (m)	5	10	15	20	25	30	35	40	45	50
h (m)	Rp (m)									
20	43.30	48.99	54.54	60.00	65.38	70.71	75.99	81.24	86.46	91.65
25	45.83	51.23	56.57	61.85	67.08	72.28	77.46	82.61	87.75	92.87
30	47.70	52.92	58.09	63.25	68.37	73.48	78.58	83.67	88.74	93.81
35	48.99	54.08	59.16	64.23	69.28	74.33	79.37	84.41	89.44	94.47
40	49.75	54.77	59.79	64.81	69.82	74.83	79.84	84.85	89.88	94.87
45	50.00	55.00	60.00	65.00	70.00	75.00	80.00	85.00	90.00	95.00
50	50.00	55.00	60.00	65.00	70.00	75.00	80.00	85.00	90.00	95.00
55	50.00	55.00	60.00	65.00	70.00	75.00	80.00	85.00	90.00	95.00
60	50.00	55.00	60.00	65.00	70.00	75.00	80.00	85.00	90.00	95.00

D (m) is the striking distance or rolling sphere radius.

$\Delta L$ (m) is the triggering advance of the E.S.E. lightning conductor considered.

h(m) is the height difference between the air terminal tip and the horizontal plane considered.

Rp(m) is the protection radius in the horizontal plane considered.

**Figure 2.2.3.3. (b)**  
**Radii of protection of the E.S.E. lightning conductors**  
**Level of protection II (D = 45 m)**

D=60m

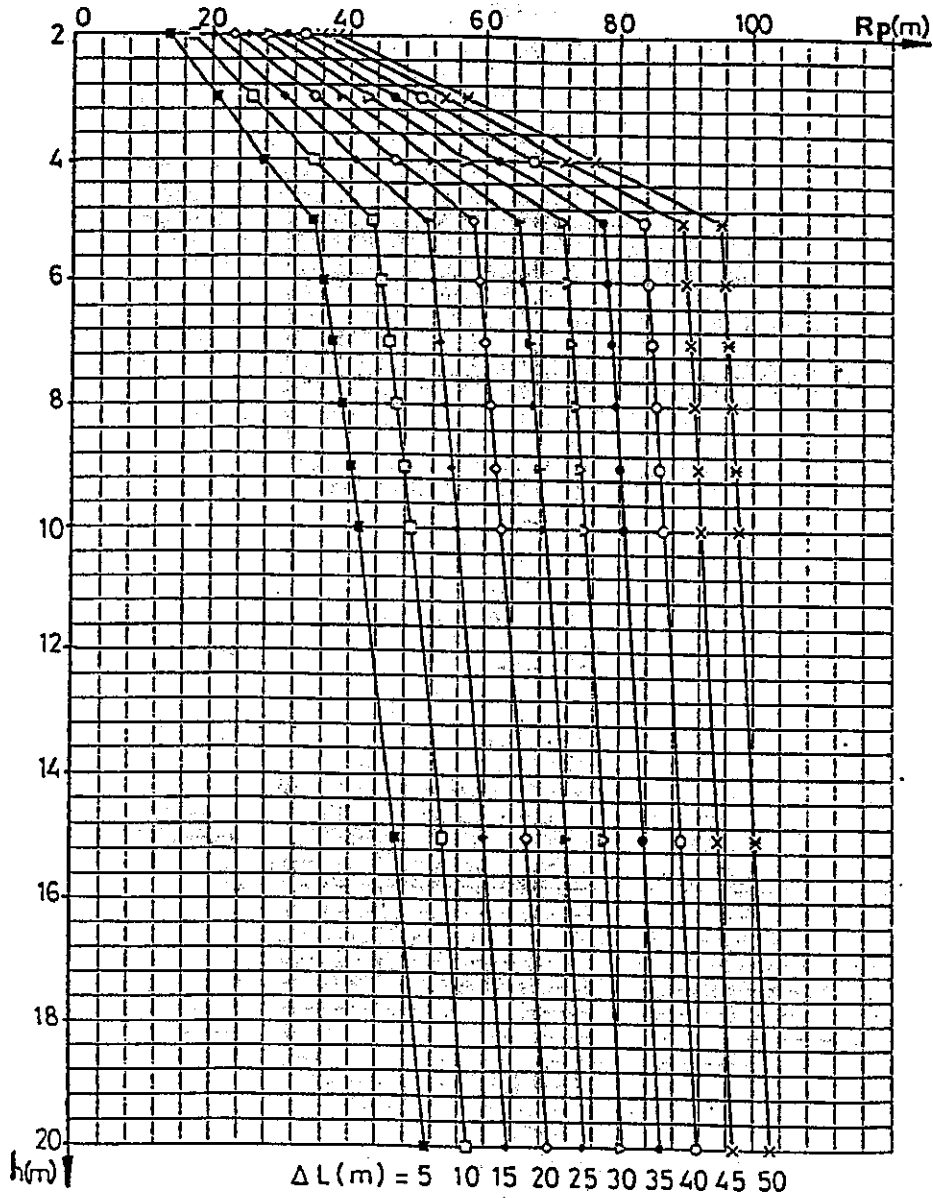

Radii of protection for h = 20 to 60m

D (m)										
60										
ΔL (m)	5	10	15	20	25	30	35	40	45	50
h (m)	Rp (m)									
20	51.23	57.45	63.44	69.28	75.00	80.62	86.17	91.65	97.08	102.47
25	54.77	60.62	66.33	71.94	77.48	82.92	88.32	93.67	98.99	104.28
30	57.66	63.25	68.74	74.15	79.53	84.85	90.14	95.39	100.62	105.83
35	60.00	65.38	70.71	75.99	81.24	86.48	91.65	96.82	101.98	107.12
40	61.85	67.08	72.28	77.46	82.61	87.75	92.87	97.98	103.08	108.17
45	63.25	68.37	73.48	78.58	83.67	88.74	93.81	98.87	103.92	108.97
50	64.23	69.28	74.33	79.37	84.41	89.44	94.47	99.50	104.52	109.54
55	64.81	69.82	74.83	79.84	84.85	89.86	94.87	99.87	104.88	109.89
60	65.00	70.00	75.00	80.00	85.00	90.00	95.00	100.00	105.00	110.00

$D$  (m) is the striking distance or rolling sphere radius.

$\Delta L$  (m) is the triggering advance of the E.S.E. lightning conductor considered.

$h$  (m) is the height difference between the air terminal tip and the horizontal plane considered.

$R_p$  (m) is the protection radius in the horizontal plane considered.

Figure 2.2.3.3. (c)  
Radii of protection of the E.S.E. lightning conductors  
Level of protection III ( $D = 60$  m)

## 2.2.4 Materials and dimensions

The E.S.E. lightning conductor part(s) through which lightning current flows should be made of copper, copper alloy or stainless steel. The rod and the air terminal tip should have a conductive cross-sectional area larger than  $120 \text{ mm}^2$ .

## 2.2.5 Positioning

### 2.2.5.1 E.S.E. lightning conductor

The E.S.E. lightning conductor tip should be at least 2 metres higher than the area that it protects, including antennae, cooling towers, roofs, tanks, etc.

The down-conductor is attached to the E.S.E. lightning conductor by a connecting system located on the support rod. This connecting system consists of a suitable mechanical device providing long-lasting electrical contact.

If the external installation for a given structure comprises several E.S.E. lightning conductors, these are interconnected by a conductor complying with the data in table 2.3.4, unless it has to be routed over a structural obstacle (cornice, parapet wall) with a positive or negative level difference in excess of 1.50m (see figure 2.2.5.1).

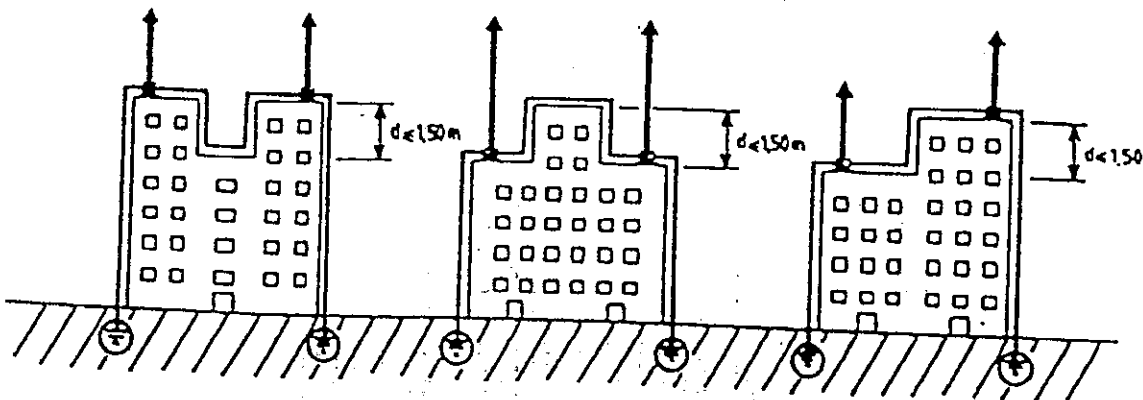

Figure 2.2.5.1

When E.S.E. lightning conductors protect open areas such as playing fields, golf courses, swimming pools, camping sites, etc., they should be installed on specific supports such as lightning poles, pylons, or any other nearby structures which enable the E.S.E. lightning conductor to cover the area to be protected.

### 2.2.5.2 Elevation masts

The E.S.E. lightning conductor height may be increased by means of an elevation mast. If the E.S.E. lightning conductor is steadied by conductive guy lines, these should be connected at the bottom attaching points to the down-conductors, by means of conductors complying with table 2.3.4.

### 2.2.5.3 Preferred installation points

The architectural features favourable to the E.S.E. lightning conductor installation should be taken into account during the lightning protection system design. Usually, these features are high structural points, such as :

- equipment rooms on flat roofs,
- gables,
- metal or masonry chimneys.

## 2.3 DOWN-CONDUCTORS

### 2.3.1 General principles

Down-conductors are designed to let the lightning current flow from the air-termination systems to the earth termination system. The down-conductors should be installed outside of the structure, except in the cases mentioned in 2.3.3.1.

### 2.3.2 Number of down-conductors

Each E.S.E. lightning conductor should be connected to the earth termination system by at least one down-conductor. Two or more down-conductors are required when :

- the horizontal projection of the conductor is larger than its vertical projection (see figure 2.3.2).
- ELPIs are installed on structures higher than 28m.

The down-conductors should be installed on two different main walls.

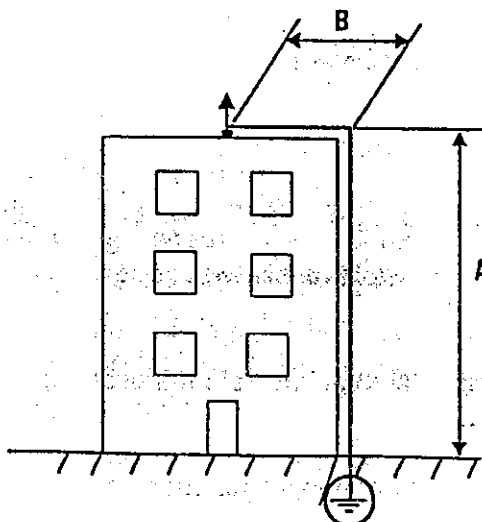

$A < 28\text{m}$  and  $A > B$  : 1 down-conductor

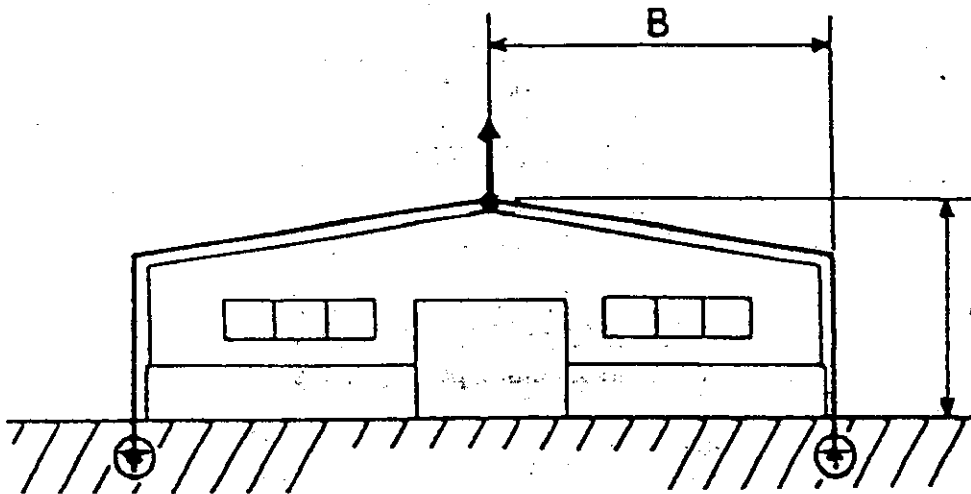

$A > 28\text{m}$  or  $A < B$  : 2 down-conductors

A : Vertical projection of down conductor

B : Horizontal projection of down conductor

Figure 2.3.2 - Number of down-conductors

### 2.3.3 Routing

The down-conductor should be installed in such a way that its path is as direct as possible. The down-conductor routing should take into account the earth termination location (see 2.5.2). It should be as straight as possible along the shortest path without sharp bends or upward sections. The bend radii should not be less than 20 cm (see figure 2.3.3). For the diverting of down-conductors, bends formed edgewise should preferably be used.

The down-conductors should not be routed along or across electrical conduits. However, when electrical conduit crossing is unavoidable, the electrical conduit should be placed inside a metal screen which extends 1m beyond the point of crossing. The screen should be connected to the down-conductor.

Routing round parapet walls or cornices should be avoided. Provisions should be made to ensure that down-conductor paths are as direct as possible. However, a maximum height increase of 40cm is permissible for passing over a parapet wall with a slope of  $45^\circ$  or less (see figure 2.3.3 e).

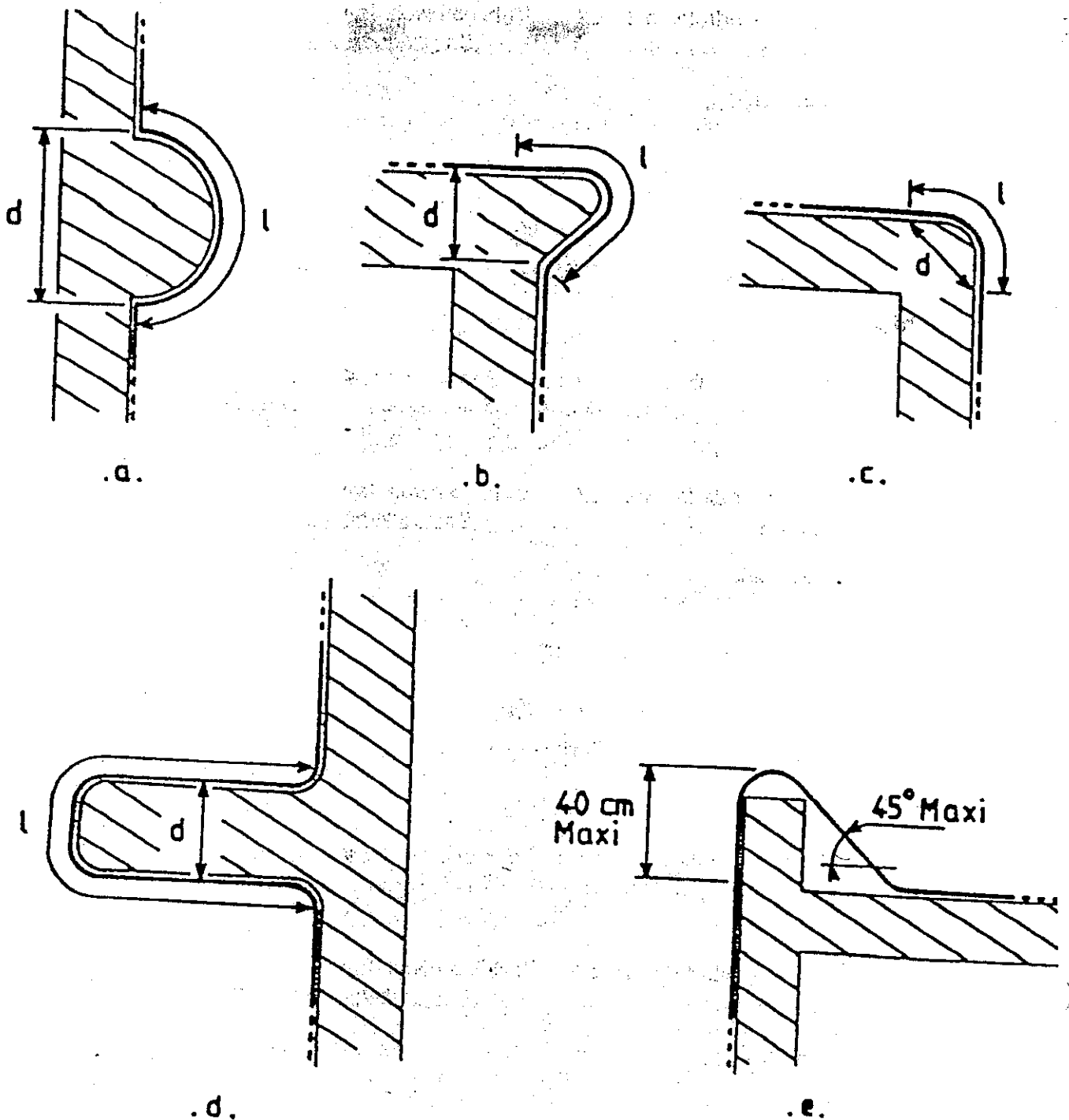

$l$  = length of the loop in metres,  
 $d$  = width of the loop in metres.

No risk of dielectric breakdown if the requirement  $d > l/20$  is met

Figure 2.3.3. LPS down-conductor bend shapes

The down-conductors should be attached on the basis of three fixings per metre. The fixings should be suitable for the supports and their installation should not alter the roof water-tightness. The fixings should allow for possible thermal expansion of the conductors.

All the conductors should be connected together by means of clamps of the same material, or by solid rivets, soldering or brazing. Drilling through down-conductors should be avoided wherever possible.

Down-conductors should be protected against the risk of impact by installing sleeves up to a height of 2m above ground level.

### 2.3.3.1 Internal routing

When external routing is impracticable, the down-conductor may be routed inside a specific service duct running along the full height or part of the height of the building.

Insulating non-flammable internal ducts may be used when their internal cross-sectional area is 2000 mm<sup>2</sup> or more. The proximity requirements stated in chapters 2 and 3 should be complied with in all cases.

The down-conductor system effectiveness may be reduced by internal routing. The project manager must be aware of the reduced lightning protection system effectiveness, inspection and maintenance difficulties, and the risks resulting from the entry of voltage surges into structures.

### 2.3.3.2 External cladding

When the outside of a building or structure has a metal cladding or stone or glass curtain-walls, or in the case of a fixed cladding item, the down-conductor may be attached behind the cladding to the concrete wall or the load-bearing structure.

In such a case, the conductive cladding components and the supporting structure must be bonded to the down-conductor at the top and bottom ends.

## 2.3.4 Materials and dimensions

Down-conductors consist of strips, braided cables, or round sections. Their minimum cross-sectional area of 50mm<sup>2</sup> is defined in table 2.3.4.

Down-conductors		
Material	Remarks	Minimum dimensions
Bare or tin-plated electrolytic copper (1)	Recommended for its good conductivity and corrosion resistance.	Strip : 30x2mm Round section : 8mm dia. (2) Braided cable : 30x3.5mm
18/10 - 304 stainless steel	Recommended in certain corrosive environments.	Strip : 30x2mm Round section : 8mm dia. (2)
A 5/L aluminium	To be used on aluminium surfaces (cladding, curtain-walls).	Strip : 30x3mm Round section : 10mm dia. (2)

Table 2.3.4

The use of insulated coaxial cables as down-conductors is not permitted. The use of insulating sheaths or coatings around down-conductors is not permitted except for the cases described in 5.2.

Notes :

- (1) Tin-plated copper is recommended in view of its physical, mechanical and electrical properties (conductivity, malleability, corrosion resistance, etc.).
- (2) As the lightning current has an impulse characteristic, the flat conductor is preferred to the round conductor since its outside surface area is larger for a given cross-sectional area.

### 2.3.5 Test clamp/Disconnect terminal (or test terminal)

Each down-conductor should be provided with a test clamp used to disconnect the earth termination system for measuring it. The test clamp should bear the term "lightning conductor" and the symbol  $\ominus$ .

Test clamps are usually installed on the down-conductors at height of about 2 m above ground level. When lightning protection systems have metal walls or are not provided with specific down-conductors, test clamps are inserted in between each earthing system and the metal building item to which the earth termination system is connected; the test clamps are installed inside inspection chambers which bear the symbol  $\ominus$ .

### 2.3.6 Lightning flash counter

When a lightning flash counter is provided, it should be installed on the most direct down-conductor above the test clamp and, in any case, at height of about 2m above ground level.

### 2.3.7 Natural components

Some conductive structural components may be used in place of an entire down-conductor or part thereof, or supplement the down-conductor.

#### 2.3.7.1 *Natural components which can be used in place of the entire down-conductor or part thereof*

Generally, external interconnected steel frames (metal structures) can be used as down-conductors in so far as they are conductive and their resistance is  $0.01 \Omega$  or less.

In such a case, the upper end of E.S.E. lightning conductors is connected directly to the metal frame whose lower end is to be connected to the earth termination systems.

The use of a natural down-conductor should meet the equipotential bonding requirements stated in chapter 3.

As natural components may be modified or removed without the fact that belong to a lightning protection system being taken into account, specific ductors should be preferred.

### *atural components which can be used to supplement down-conductor(s)*

following items can be used to supplement the lightning protection system and connected to it :

interconnected steel frames providing electrical continuity :

- internal metal structures, concrete reinforcements and metal structures sunk into walls, subject to specific connection terminals being provided for this purpose in the upper section and lower section (at least in three points at each level);
- external metal structures which do not run over the entire structure height.

Note : When prestressed concrete is used, special attention should be paid to the risk of mechanical effects due to the lightning current flowing through the lightning protection system.

metal sheets covering the area to be protected, provided that :

- long-lasting electrical continuity is provided between all the parts;
- metal plates are not coated with insulating material.

Note : A light coat of protective paint, a 1mm thick asphalt film or a 0.5mm thick PVC film is not considered as an insulation.

metal pipes and tanks if made of material 2mm thick or more.

## **EQUIPOTENTIAL BONDING OF METAL PARTS AND INTERNAL LIGHTNING PROTECTION INSTALLATION**

### **GENERAL**

When lightning current flows through a conductor, differences of potential appear between this conductor and nearby earthed metal parts. Dangerous sparks may be produced across the ends of the resulting open loop.

Depending on the distance between the ends of the open loop (down-conductor(s) and earthed metal part), equipotential bonding may or may not be achieved. The minimum distance at which no dangerous sparks can be produced is known as the safety distance  $s$  and depends on the selected protection level, the number of down-conductors, the material between the loop ends, and the distance from the metal part considered to earth connection point.

It is often difficult to provide for insulation during the installation of the lightning protection system (through lack of information needed to take a decision), or to provide for long-term insulation (structural changes, work, etc.). Equipotential bonding is therefore frequently preferred.

However, equipotential bonding is not provided in some cases (flammable or explosive piping). The down-conductors are then routed further away than the safety distance  $s$  (see 3.2.1(c)).

### 3.1.1 Equipotential bonding

The equipotential bonding should be provided wherever possible at the closest point by an equipotential conductor, a lightning arrester or a spark gap, between the down-conductor or the E.S.E. lightning conductor draining the lightning current and the component to be put at the same potential and located on the structure, in the structure walls or inside the structure.

### 3.1.2 Safety distance

The safety distance is the minimum distance at which no dangerous spark is produced between a down-conductor draining the lightning current and a nearby earthed conductive mass (see figure 4.5).

The insulation with respect to dangerous sparks is achieved when the distance  $d$  between the lightning protection system and the conductive item considered is more than  $ds$ .

$$\text{Safety distance : } s(m) = n \cdot \frac{k_j}{k_m} \cdot l(m) \quad (\text{Equation 3})$$

where :

-  $n$  is the number of down-conductors for each E.S.E. lightning conductor before the contact point considered :

$n = 1$  for one down-conductor,  
 $n = 0.6$  for two down-conductors,  
 $n = 0.4$  for three or more down-conductors.

-  $k_j$  is a factor related to the selected protection level :

$k_j = 0.1$  for protection level I,  
 $k_j = 0.075$  for protection level II,  
 $k_j = 0.05$  for protection level III.

-  $k_m$  is a factor related to the material used between the two loop ends :

$k_m = 1$  for air,  
 $k_m = 0.5$  for a solid material which is not a metal.

-  $l$  (in meters) is the length along the down-conductor(s) from the point where the proximity is to be considered to the earthing system of the metal part or the nearest equipotential bonding point.

Notes :

- (1) When the nearby conductive part is not electrically earthed, it is not necessary to provide an equipotential bonding.
- (2) When the LPS is connected to reinforced concrete structures with interconnected reinforcing steel and in case of steel frame structures or of structures equivalent screening performance, proximity requirements are usually met.

### **3.2 EQUIPOTENTIAL BONDING OF EXTERNAL METAL MASSES**

In most cases, a connection using an equipotential conductor is possible. If it is not possible or authorised by the competent authorities, the connection must be made using a surge protective device.

#### **3.2.1 Equipotential bonding using an equipotential conductor**

Equipotential bonding should be provided at the following locations :

- (a) Above the ground and underground.

All the structure earth terminals should be interconnected as provided for in paragraphs 4.4 and 4.5.

- (b) Whenever the proximity requirements are not met : when  $d < s$ .

In such a case, the acceptable equipotential conductors should be of the same type as those used to make down-conductors (table 2.3.4). They should be kept as short as possible.

In the event of a lightning protection system separated from the structure to be protected, the equipotential bonding should be made at ground level only.

- (c) In the case of gas service pipes located downstream of the insulating sleeve,  $s=3m$ .

#### **3.2.2 Equipotential bonding using a surge protective device**

An antenna or a small post supporting electrical lines should be bonded at the nearest to the down-conductor, via a antenna-mast spark-gap type surge protective device.

If pipe lines (water, gas, etc.) with insulated parts are laid within the space considered, such insulated parts should be by-passed by the surge protective device.

### **3.3 EQUIPOTENTIAL BONDING OF METAL PARTS SUNK INTO WALLS**

The guidelines stated in paragraphs 3.2.1(a) and (b) are still applicable in so far as connecting terminals have been provided for this purpose in the relevant batches. Special attention should be paid to water-tightness problems.

Note : For existing structures, the competent authorities should be contacted.

### **3.4 EQUIPOTENTIAL BONDING OF INTERNAL METAL PARTS : INTERNAL LIGHTING PROTECTION INSTALLATION**

Equipotential conductors should be used to connect internal metal parts to an equipotential bonding bar made and laid out in such a way as to allow easy disconnection for inspection purposes. The minimum cross-sectional area of such conductors should be  $16 \text{ mm}^2$  when they are made of copper or aluminium, or  $50 \text{ mm}^2$  when they are made of steel. The equipotential bonding bar should be connected to a point as close to the structure earthing circuit as possible. For large structures, several equipotential bonding bars may be installed provided that they are interconnected. Each equipotential bonding bar should be made of copper or the same material as the equipotential conductor and its minimum cross-sectional area should be  $75 \text{ mm}^2$ .

For electrical or telecommunication systems, using screened conductors, or conductors installed inside a metal conduit, earthing the screens or metal conduits usually provides sufficient protection.

If not, the active conductors should be bonded to the lightning protection system via surge protective devices.

## **4. EARTH TERMINATION SYSTEMS**

### **4.1 GENERAL**

One earth termination system is provided for each down-conductor.

To allow for the impulse characteristic of the lightning current and to enhance current draining to earth, while minimising the risk of dangerous voltage surges within the protected volume, it is also important to pay attention to the earth termination system shape and dimensions and also to the earth termination resistance value.

Earth termination systems should meet the following requirements :

- the resistance value measured using a conventional equipment should be 10 ohms or less. This resistance should be measured on the earthing termination insulated from any other conductive component.
- the wave impedance or inductance value should be as low as possible in order to minimise the back-electromotive force which is added to the ohmic potential rise occurring during the lightning discharge. For this purpose, earth termination systems having a single excessively long horizontal or vertical component should not be used.

The use of a single vertical termination system deeply buried to reach a humid layer of soil is thus not advantageous unless the surface resistivity is particularly high.

It should however be noted that such drilled earth termination systems have a high wave impedance when the depth exceeds 20 metres. This calls for the use of a greater number of horizontal conductors or vertical stakes which must always be perfectly interconnected from an electrical standpoint. Similarly, copper conductors should be preferred to steel conductors whose cross-sectional area required to achieve equivalent conductivity makes their use impracticable.

Earth termination systems should be made and laid out as stated above and in section 544 of standard NF C 15-100.

Unless there is a real impossibility, earth termination systems should always be directed outward from the buildings.

## 4.2 EARTH TERMINATION SYSTEM TYPES

The earth termination system dimensions depend on the soil resistivity in which the earth termination systems are installed. The resistivity may vary to a considerable extent depending on the soil material (clay, marl, sand, rock, etc.).

The resistivity can be assessed from the table below, or measured using a suitable method with an earth ohmmeter.

Once the resistivity is known, the length of an termination system can be determined using the following simplified equations :

Linear horizontal termination system    Vertical termination system

$$L = 2\rho/R \text{ (Equation 4)} \quad L = \rho/R \text{ (Equation 5)}$$

where :

L is the termination system length (in m)

$\rho$  is the soil resistivity (in  $\Omega.m$ )

R is the desired resistance value ( $\leq 10 \Omega$ ).

Soil	Resistivity in $\Omega.m$
Swampy terrain	a few units up to 30
Silt	20-100
Humus	10-150
Humid peat	5-100
Soft clay	50
Marl and compact clay	100-200
Jurassic marl	30-40
Clayey sand	50-500
Siliceous sand	200-3000
Bare stony soil	1500-3000
Grass covered stony soil	300-500
Soft limestone	100-300
Compact limestone	1000-5000
Cracked limestone	500-1000
Schist	50-300
Mica schist	800
Granite and sandstone depending on alteration	1500-10000
Granite and sandstone little altered	100-600

**Table 4.2**

For each down-conductor, the earth termination systems should at least consist of :

- (a) conductors of the same material and cross-sectional area as the down-conductors, except for aluminium, arranged in crow's foot fashion and buried at a minimum depth of 50 cm.

Example : three 7-8-metre long conductors, buried horizontally at a minimum depth of 50 cm; or

- b) a set of several vertical stakes totalling a minimum length of 6 metres.
- arranged in line or as a triangle and separated from each other by a distance equal to at least the buried length;
  - interconnected by a conductor which is identical to or has characteristics compatible with the down-conductor, and buried in a trench at a minimum depth of 50 cm.

Note : The recommended lay-out is the triangle.

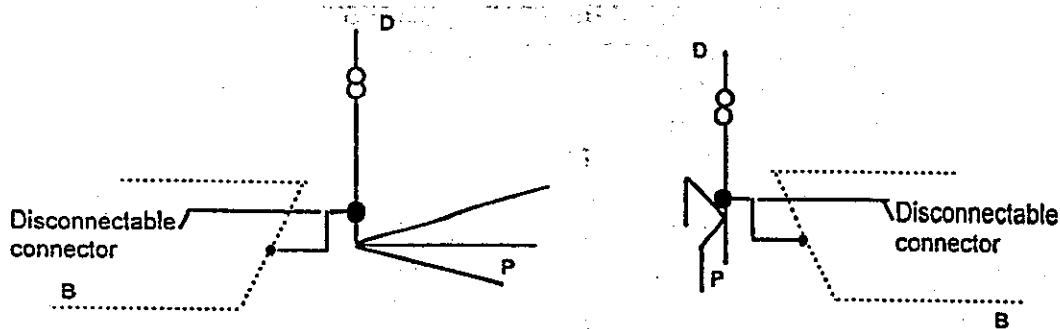

D : Down-conductor  
 B : Building foundation loop earth  
 P : Lightning earth termination system

Figure 4.2 - Typical earth termination system diagrams

#### 4.3 ADDITIONAL MEASURES

When the high soil resistivity makes it impossible to achieve an earth termination system resistance lower than 10 ohms using the above standard protective measures, the following additional measures may be used :

- add natural material with a lower resistivity around the earth conductors;
- add earth rods to the crow's feet or to the stakes already installed;
- augment the number of earth termination systems and interconnect them;
- apply a treatment which reduces the impedance and features high current draining capacity;
- when all the above measures are adopted and a resistance value of less than 10 ohms cannot be obtained, it can be considered that the earth termination system provides acceptable lightning current draining when it consists of a buried termination system at least 100m long, assuming that each vertical or horizontal element is not more than 20 m long.

#### 4.4 EARTH TERMINATION SYSTEM INTERCONNECTION

When the building or the protected volume has a foundation earth termination system for the electrical system in compliance with article 542.2 of standard NF C 15-100, the LPS earth termination systems should be connected to it by a standard sized conductor (see tables 2.3.4 and 4.6).

For new installations, this measure should be taken into account as from the design stage, and the interconnection to the foundation earth circuit should be made right in front of each down-conductor by a device which can be disconnected and located in front of an inspection chamber bearing the symbol



For existing buildings and installations, the connections should be made preferably on the buried parts and it should be possible to disconnect for inspection purposes.

When the interconnection is made inside a building, the interconnecting conductor should be routed in such a way that no currents are induced in nearby cables or equipment.

When several separate structures are included in the protected volume, the E.S.E. lightning conductor earth termination system should be connected to the buried equipotential earth network interconnecting all the structures.

#### 4.5 PROXIMITY REQUIREMENTS

The LPS earth termination components should be at minimum distances away from any buried metal pipe or electrical conduit.

The minimum distances are indicated in table 4.5 hereunder :

Buried services	Minimum distances	
	Soil resistivity $\leq 500 \Omega.m$	Soil resistivity $> 500 \Omega.m$
Electrical conduit HTA	0.5	0.5
Electrical conduit LV without earth termination system	2	5
Earth termination system LV mains supply	10	20
Metal pipes for gas	2	5

Table 4.5

These distances are applicable only with conduits which are not electrically connected to the main equipotential link of the building.

Note : In the case of non metal conduits, compliance with a minimum distance is not required.

#### 4.6 MATERIALS AND DIMENSIONS

The materials and the minimum dimensions for the earth termination systems are given in the table below.

Earth termination systems		
Material	Recommendations	Minimum dimensions
Bare or tin-plated electrolytic copper (1)	Recommended for the good conductivity and corrosion resistance.	Strip : 30x2mm Round section : 8mm dia. Grid made of wire with a min. cross-sectional area of 10 mm <sup>2</sup> Solid stake : 15mm dia., 1m lg Tubular rod : 25mm O.D., 1m lg
Copper-plated steel (250µm)		Rod : 15mm dia., 1m lg
18/10 - 304 stainless steel	Recommended in certain corrosive soils.	Strip : 30x2mm Round section : 10mm dia. Rod : 15mm dia.
Hot-galvanised steel (50µm)	Reserved for provisional short-term installations because of its poor corrosion resistance.	Strip : 30x3.5mm Round section : 10mm dia. Rod : 19mm dia., 1m lg

Table 4.6

Note : (1) Tin-plated copper is recommended in view of its physical, mechanical and electrical properties (conductivity, malleability, corrosion resistance, etc.).

## 5. ANTICORROSION PROTECTION

### 5.1 GENERAL

The corrosion of metals depends on the type of metal used and on the characteristics of the metal environment. Factors such as fungus, soluble salts (electrolytes), degree of ventilation, electrolyte temperature and changes make the conditions highly complicated.

The contact of dissimilar metals associated with electrolysis phenomena due to the environment increases corrosion in more anodic or active metal and decreases corrosion in more cathodic or inert metal. Corrosion in more cathodic metal should be prevented. The electrolyte for this reaction may be a humid soil, or condensation retained in cracks.

### 5.2 PRECAUTIONS AND MEASURES TO BE TAKEN

In order to reduce corrosion, it is necessary to :

- avoid the use of unsuitable metals in an aggressive environment,
- avoid contacts between dissimilar metals with different galvanic couples,
- use conductors of appropriate gauges and corrosion-resisting fasteners,

- provide protective coatings in critical cases as appropriate to the external influences.

To meet the above requirements, the following precautions are given as typical examples :

- the minimum thickness or diameter of a conductive item should comply with the provisions of this standard,
- aluminium conductors should not be buried or embedded directly in concrete, unless they are provided with a suitable long-lasting sheath,
- copper/aluminium joints should be avoided wherever possible. If unavoidable, joints should be made using suitable two-metal connections.
- copper is usually suitable for earthing, except under certain acid conditions, when exposed to oxygen or sulphate,
- when there are sulphuric or ammoniacal fumes, a coating may be used on the down-conductors.

Note : The use of insulating material of thickness less or equal to 0.5 mm is admitted.

- conductor fasteners should be made of stainless steel or a suitable synthetic material under corrosive environmental conditions.

## 6. SPECIAL MEASURES

### 6.1 ANTENNAE

An antenna on the roof of a building increases the lightning stroke probability and is the first vulnerable item likely to receive the lightning discharge.

When this is an individual or collective radiobroadcasting receiver antenna, complying with the standard\*, the antenna support mast should be connected through a surge protective device or a spark gap to the down-conductors of the installation by a standard conductor unless the antenna is outside the protected area or on another roof.

A common support mast can be used under the following conditions :

- the common support mast consists of adequately strong tubes which do not need guy lines,
- the E.S.E. lightning conductor is attached to the tip of the mast,

---

\* Matériel électronique et de télécommunications - Antennes individuelles ou collectives de radiodiffusion sonore ou visuelle : Règles (Standard NF C 90-120 - October 1983, published by Union Technique de l'électricité).

- the E.S.E. lightning conductor tip is at least 2 m above the nearest antenna,
- the down-conductor is attached by a clamp which is fastened directly onto the rod,
- the antenna coaxial cable is routed inside the mast antenna.

In the case of a lattice mast, it is preferable to route the coaxial cable through a metal tube.

## 6.2 THATCHED ROOFS

In this case, the E.S.E. lightning conductor should preferably be installed on the chimney if it exists. The down-conductor should be an 8mm diameter annealed-copper round conductor which should be routed along the roof ridge on stand-off insulators with a clear space of 20-25cm and down on thatch gutters.

## 6.3 FACTORY CHIMNEYS

As factory chimneys are very tall and smoke and hot gasses ionise the air, they are highly prone to being struck by lightning.

The upper part of the chimney should be provided with a E.S.E. lightning conductor, preferably using materials suited to the corrosive atmosphere and exhaust temperature, and located on the prevailing wind side.

For chimney height 40 metres high or more, two down-conductors minimum should be installed diametrically opposed with one being located on the prevailing wind side. These down-conductors should be interconnected at the upper end and at the base of the chimney by an horizontal conductor. Each down-conductor should be provided with an earth termination system.

The external and internal metal items should be connected to the nearest down-conductor under the same conditions as those stated in Chapter 3.

## 6.4 FLAMMABLE AND EXPLOSIVE MATERIAL STORAGE AREAS

In compliance with the current regulations, tanks containing flammable fluids should be earthed but such an earth connection does not provide adequate protection against atmospheric discharges. A thorough additional survey is therefore necessary.

E.S.E. lightning conductors should be erected on masts, poles, pylons, or any other structure outside the safety area so as to be above the installations to be protected. Their location should take the protection radii into account in accordance with this standard.

Earth termination systems should be oriented away from the storage installations. The E.S.E. lightning conductor and protected installation earth termination systems should be equipotential.

Note : The Ministerial Decree dated January 28, 1993 concerning the lightning protection of certain classified installations makes the installation of lightning stroke counters compulsory.

## 6.5 RELIGIOUS BUILDINGS

Steeple, towers, minarets and belfries are prone to being struck by lightning because of their prominence.

The main prominence(s) should be protected with E.S.E. lightning conductors connected to the ground by a direct down-conductor routed along the main tower.

A second down-conductor following the nave ridge should be provided when one or more of the following conditions is met :

- the total steeple height exceeds 40 metres,
- because of its length, the nave extends outside the E.S.E. lightning conductor protection area.

In this case, the second down-conductor should originate from the summit of the main tower.

When a church is fitted with two down-conductors, and the end of the nave is fitted with a non-metallic cross or statue, the cross or statue will be provided with a air terminal.

Both LPS earth termination systems and the electric earth are preferably interconnected by an earth conductor.

Some religious buildings have electric bells. The electrical power supply is protected against voltage surges by lightning arresters complying with article 3.

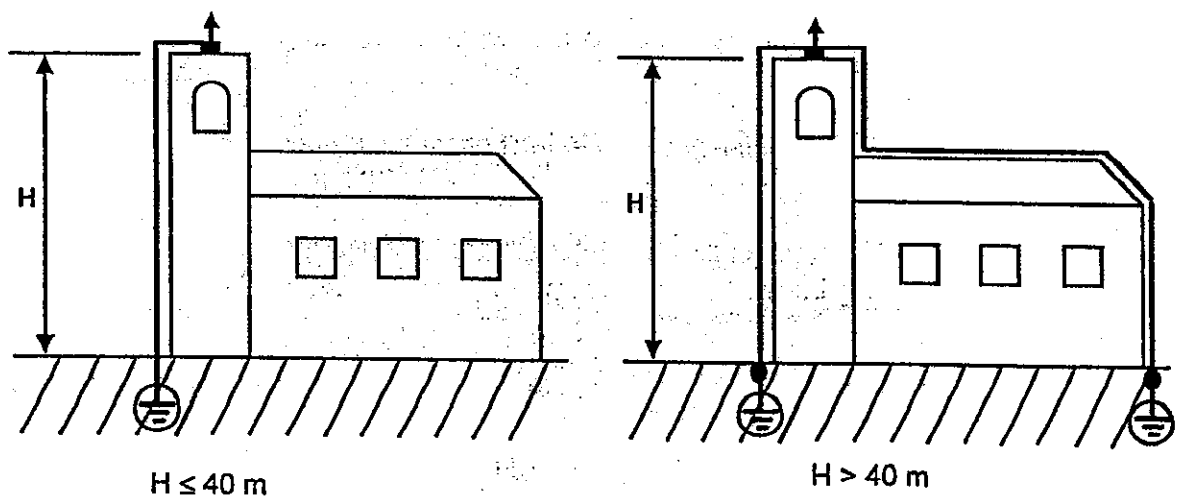

Figure 6.5 - Religious building

## **6.6 STRUCTURES OF ALTITUDE**

Mountain restaurants, refuges, cableway stations are particularly prone to being struck by lightning. The E.S.E. lightning conductors may be installed in compliance with the provisions of this standard, paying special attention to the equipotential bonding and earth termination systems.

## **6.7 OPEN AREAS, LEISURE OR SPORTS AREAS**

Play fields, camping and caravan sites, swimming pools, racecourses, motor racing circuits, amusement parks, etc.

The E.S.E. lightning conductors are installed on flagpoles, floodlight masts, pylons, or any other existing structure. Their number and location depend on the type and area of the surfaces to be protected in compliance with the provisions of this standard.

## **6.8 TREES**

Certain isolated trees are potentially prone to lightning strikes because of their height and shape.

Wherever the risk of lightning strike involves hazard to close structures (e.g., nearby building), or historical or aesthetic interests are involved, the tree may be usefully protected against lightning by installing an E.S.E. lightning conductor at its top in compliance with the provisions of this standard.

The easiest way to install the down-conductor which does not hinder the tree's growth and damages it as little as possible is to use a conductor in the form of a flexible braided cable secured by suitable fasteners taking the most direct path possible along the tree trunk.

## **7. INSPECTION, MAINTENANCE**

LPS maintenance is essential since a number of components may lose their effectiveness over time due to corrosion, weather, mechanical impacts, and lightning. The mechanical and electrical characteristics of an LPS should be maintained throughout the LPS life in order to meet the standard requirements.

### **7.1 INITIAL INSPECTION**

Once the E.S.E. lightning conductor installation is completed, it should be inspected to make sure that it complies with the provisions of this standard.

The purpose of this inspection is to make sure that :

- the E.S.E. lightning conductor is 2 metres or more above the entire protected area,
- the materials and the gauges used for the down-conductors are suitable,

- the down-conductors are routed, located and electrically bonded as required,
- all the installation components are firmly secured,
- the safety distance(s) is(are) respected and/or equipotential bondings are provided,
- the earth termination system resistance values are correct,
- the earth termination systems are interconnected.

This inspection should be performed visually under the conditions stated in part 6 of standard NF C 15-100.

However, where a conductor is entirely or totally hidden, its electrical continuity should be tested. Such a test should conform to part 6 of standard NF C 15-100.

## 7.2 SCHEDULED INSPECTION

The inspection frequency is determined by the protection level. The following inspection intervals are recommended :

	Normal interval	Intensified interval
LEVEL I	2 YEARS	1 YEAR
LEVEL II	3 YEARS	2 YEARS
LEVEL III	3 YEARS	2 YEARS

Note : The intensified interval is recommended in a corrosive atmosphere.

An LPS should also be inspected whenever the protected structure is modified, repaired or when the structure has been struck by lightning.

Note : Lightning flashes can be recorded by a lightning flash counter installed on one of the down-conductors.

### 7.2.1 Inspection procedure

A visual inspection should be performed to make sure that :

- no extension or modification of the protected structure calls for the installation of additional lightning protective measures,
- the electrical continuity of visible conductors is correct,
- all component fasteners and mechanical protectors are in good condition,
- no parts have been weakened by corrosion,
- the safety distance is respected and there are enough equipotential bondings and their condition is correct.

Measurements should be taken to verify :

- the electrical continuity of hidden conductors,
- the earth termination system resistance values (any variation should be analysed).

### **7.2.2 Inspection report**

Each scheduled inspection should form the subject of a detailed report containing all the findings of the inspection and the corrective measures to be taken.

## **7.3 MAINTENANCE**

Any faults found in the LPS during a scheduled inspection should be corrected as soon as possible in order to maintain its optimal effectiveness.

# APPENDIX A

(Normative)

## PROTECTION MODEL

### A 1 ATTACHMENT PROCESS DESCRIPTION

#### A 1.1 Striking point determination

The formation or arrival of a stormy cloud creates an electrical field (ambient) between the cloud and the ground. This electrical field may exceed 5 kV/m on the ground, thereby initiating corona discharges from ground reliefs or metal parts.

The lightning stroke begins with the formation of a downward leader within the stormy cloud which propagates in steps towards the ground. The downward leader conveys electric charges which causes the ground field to build up.

An upward leader develops from a structure or an object linked to the ground. The upward leader propagates until it joins the downward leader and the lightning current flows through the resulting channel. Other upward leaders can be emitted by several ground structures. The first one which joins the downward leader determines the lightning striking point (Fig. A1).

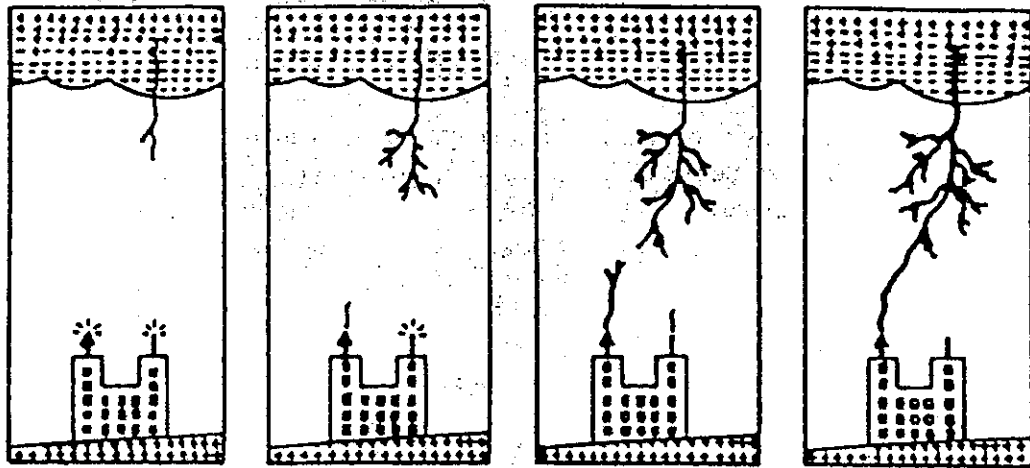

Figure A1

Note : This description only concerns the negative downward lightning stroke, which is the only application case of the electro-geometrical model. This type of lightning stroke is by far the most frequent.

#### A 1.2 Leader propagation velocity

Recent experimental data obtained from the nature shows that the average velocities of the upward and downward leaders are comparable during the attachment phase and the velocity ratio  $v_{up}/v_{down}$  is close to 1 (between 0.9 and 1.1).

Assuming that  $v = v_{up} = v_{down} = 1 \text{ m}/\mu\text{s}$  (average measured leader velocities), where :

$v_{up}$  is the upward leader velocity,  
 $v_{down}$  is the downward leader velocity,  
 $v$  is the common velocity.

## **A 2 ADVANTAGE OF AN E.S.E. LIGHTNING CONDUCTOR IN TERMS OF PROTECTION**

### **A 2.1 Triggering advance**

An E.S.E. lightning conductor is built to reduce the average statistical time related to the upward leader initiation. An E.S.E. lightning conductor features an triggering advance as compared with a simple rod lightning conductor installed under the same conditions. This gain in time is assessed in a high-voltage test laboratory as recommended in paragraph 2.2.2.1 and Appendix C to this standard.

### **A 2.2 Gain in length of the upward leader**

The gain in upward leader length  $\Delta L$  is given by  $\Delta L(\text{m}) = v(\text{m}/\mu\text{s}) \cdot \Delta T(\mu\text{s})$ .

The protected volume is determined from the protection model described above on the basis of the electro-geometrical model.

## **A 3 MODEL OF PROTECTION**

### **A 3.1 Protection radius of a S.R. lightning conductor**

In the case of a simple rod, according to the electro-geometrical model, the lightning striking point is determined by the ground object which is the first one to be located at a distance  $D$  from the downward leader even though this object is the flat ground itself. The distance  $D$  between the strike point and the upward and downward leader joining point is known as the "striking distance" : this is also the development length of the upward leader.

Therefore, it appears as if a fictitious sphere of radius  $D$  was centred on and moving rigidly with the downward leader head.

Considering a simple rod of height "h" relative to the reference surface (building roof, ground, etc.), there are three possibilities (see figure A 2) :

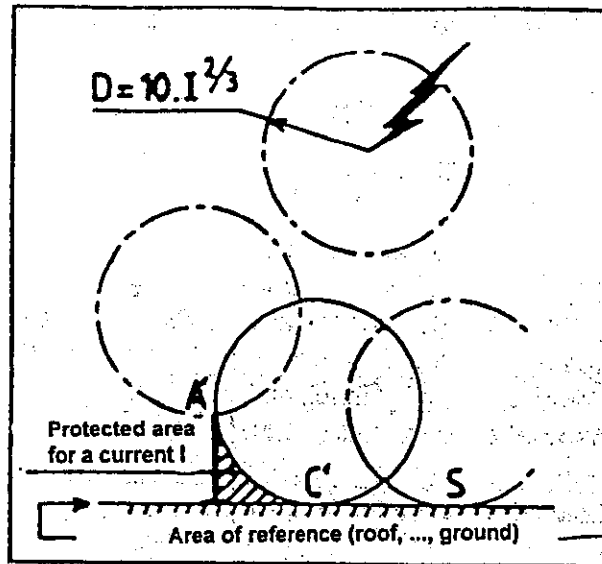

Figure A 2 - Fictitious sphere method

- if the sphere comes into contact with the vertical rod ( $A'$ ) only, the vertical rod will be the strike point,
- if the sphere comes into contact with the reference surface and not with the vertical rod, the strike point will be on the ground at  $S$  only,
- if the sphere comes into contact with both the simple rod and the reference surface at the same time, there are two possible strike points :  $A'$  and  $C'$ , but the lightning discharge will never strike the hatched area (see figure A 3).

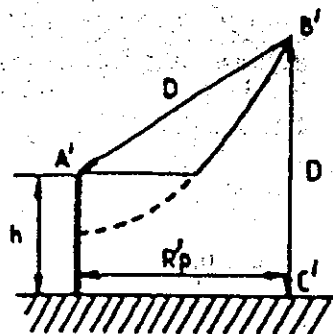

Figure A 3

The striking distance  $D$  is generally given by the following equation :

$$D(m) = 10.I^{2/3}, \text{ where}$$

$I$  is the peak current of the first return stroke in kiloAmperes (kA).

### A 3.2 Protection radius of an E.S.E. lightning conductor

In the case of an E.S.E. lightning conductor of triggering advance  $\Delta T$ , and with  $\Delta L = v.\Delta T$ , the possible strike points are  $A$  and  $C$  (Figure A 4) with a protection radius  $R_p$ , such that :

$$R_p = \sqrt{h(2D-h) + \Delta L(2D + \Delta L)}$$

where :

D is the striking distance

$\Delta L$  is the upward leader length gain defined by  $\Delta L = v \cdot \Delta T$

h is the E.S.E. lightning conductor tip height above the surface to be protected.

$R_p$  is the E.S.E. lightning conductor protection radius

$\Delta T$  is the triggering advance of the E.S.E. lightning conductor.

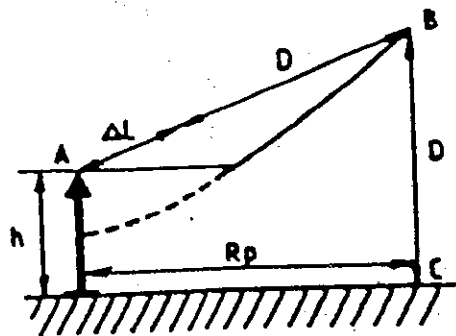

Figure A4

## APPENDIX B

(Normative)

### LIGHTNING RISK ASSESSMENT GUIDE AND SELECTION OF PROTECTION LEVEL FOR AN ELPI

#### B 1 GENERAL

The lightning risk assessment guide is intended to assist the design manager in the analysis of all the criteria used to assess the risk of damage due to lightning and to determine the need for protection and the required protection level. Only the damage caused by a direct lightning stroke on the structure to be protected and the lightning current flow through the LPS is covered.

In many cases, the need for protection is obvious. Examples are :

- large crowd,
- service continuity,
- very high lightning stroke frequency,
- tall or isolated structures,
- building containing explosive or flammable materials, or irreplaceable cultural heritage.

Some typical consequences of a lightning stroke on several types of common structures are listed in table B1 for information.

Structure classification	Structure type	Lightning consequences
Common structures (see note)	Private house	Perforation of electrical installations, fire and equipment damage normally limited to objects close to the lightning strike point or path.
	Farm	Risk of fire and dangerous sparks. Risk consequent to power failure : cattle dying as a result of the loss of ventilation control and food distribution. Risk of step voltage.
	Theatre, school, hypermarkets, sports areas	Risk of panic and fire alarm failure resulting in delayed fire fighting.
	Bank, insurance	Same as above plus problems related to loss of information and computers malfunction.
	Hospital, nursery, jail	Same as above plus problems related to patients in intensive care
	Companies, business companies	Same as above plus problems related to patients in intensive care units and evacuation of handicapped persons.
	Industry	Additional effects depending on the factory contents, ranging from minor damage to unacceptable damage and production loss.
Museums and archaeological sites	Irreplaceable losses in cultural heritage.	

Table B1

Note : Sensitive electronic equipment may be installed in any type of structures and can be easily damaged by voltage surges due to lightning.

A risk assessment method is proposed in this guide, it takes into account the lightning risk and the following factors :

1. Building environment,
2. Type of construction,
3. Structure contents,
4. Structure occupancy,
5. Lightning stroke consequences.

The building location in the environment, and the building height are taken into consideration for the computation of the exposure risk.

In some cases however, certain criteria specific to a given structure cannot be assessed and may prevail over any other consideration. Protective measures can then be applied which are more stringent than those resulting from the application of the guide.

The selection of the suitable protection level for the ELPI to be installed is based on the expected direct lightning stroke frequency on the structure or the area to be protected and on the accepted yearly lightning stroke frequency  $N_c$ .

**B 2 Determination of  $N_d$  and  $N_c$**

**B 2.1 Lightning flash density  $N_g$**

The lightning flash density is expressed as the yearly number of lightning flashes per  $km^2$  and can be determined by :

- using the stroke density map  $N_a$  in Figure B4. In this case,  $N_g = N_a / 2.2$
  - consulting a lightning location network,
  - using the local isokeraunic level  $N_k : N_{g,max} = 0.04 N_k, 1.25 \leq N_k / 10$
- } with  $N_{g,max} = 2 N_g$

The value  $N_{g,max}$  takes into account the maximum lightning density and the precision of detection.

$N_k$	5	10	15	20	25	30	35	40	45
$N_{g,max}$	0.3	0.7	1.2	1.7	2.2	2.8	3.4	4.0	4.7

Note : The map of figure B4 shows the stroke density. The constant 2.2 is the average ratio of the number of strokes to the number of flashes.

## B 2.2 Expected frequency $N_d$ of direct lightning to a structure

The yearly average frequency  $N_d$  of direct lightning to a structure is assessed using the following equation :

$$N_d = N_g \max. A_e \cdot C_1 10^{-6} / \text{year, where : (Equation 6)}$$

$N_g$  is the yearly average lightning flash density in the region where the structure is located (number of lightning flashes/year/km<sup>2</sup>);

$A_e$  is the equivalent collection area of the isolated structure (m<sup>2</sup>);

$C_1$  is the environmental coefficient.

The equivalent collection area is defined as the ground area having the same yearly direct lightning flash probability as the structure.

According to table B2, the equivalent collection area  $A_e$  for isolated structures is defined as an area of ground surface which has the same annual frequency of direct lightning as the structure. It is the area between the lines obtained by the intersection of the ground surface and 1 :3 slope line passing through the top of the structure and revolving around the structure (see figure B3).

For a rectangular structure with length  $L$ , width  $W$  and height  $H$ , the collection area is then equal to :

$$A_e = LW + 6H(L + W) + 9\pi H^2 \text{ (Equation 7)}$$

The topography of the site and the objects located within the distance  $3H$  from the structure significantly affect the collection area. This effect is taken into account by applying environmental coefficient  $C_1$  (table B2).

Relative structure location	$C_1$
Structure located within a space containing structures or trees of the same height or taller	0.25
Structure surrounded by smaller structures	0.5
Isolated structure : no other structures within a distance of $3H$	1
Isolated structure on a hilltop or a headland	2

Table B2 - Determination of environmental coefficient  $C_1$

- When the equivalent collection area of a structure entirely covers that of another structure, the latter is disregarded.
- When the collection areas of several structures are overlapped, the corresponding common collection area is considered as a single collection area.

Note : Other more sophisticated methods may be used to assess the equivalent collection area with greater accuracy.

### Figures B3 - Typical computations

1°) For a rectangular building, the collection area is :  $A_e = L \times W + 6H(L + W) + 9\pi H^2$

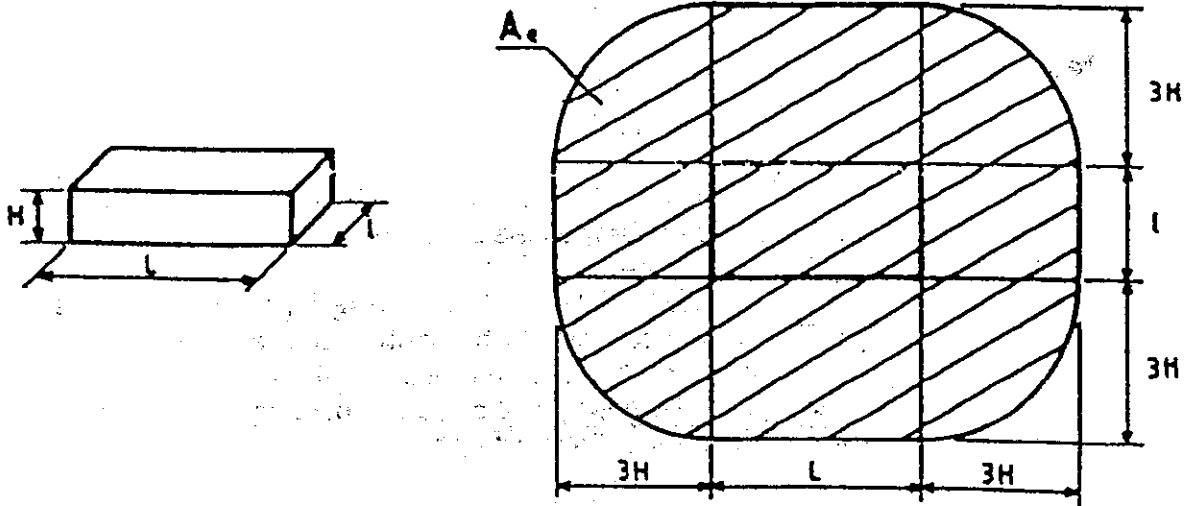

2°) Building with a prominent part

The equivalent area of the prominent part encompasses all or part of the lower part:

2.1.  $A_e = 9\pi H^2$

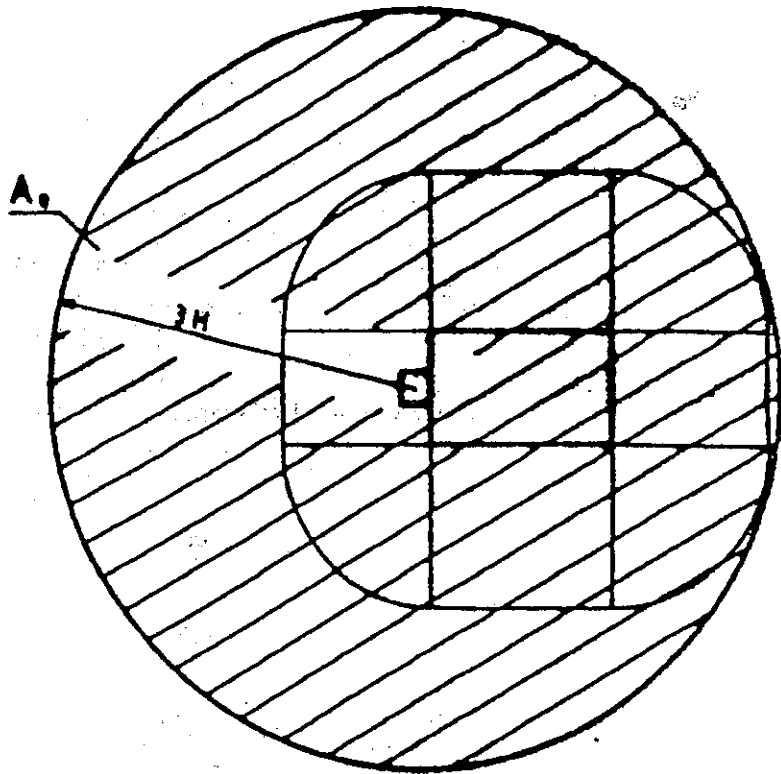
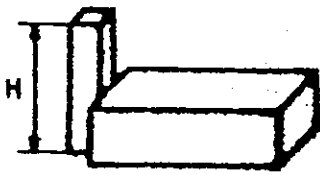

2.2.

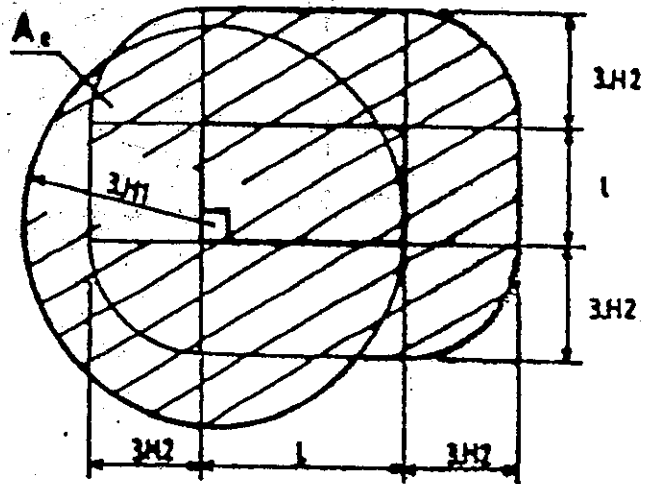
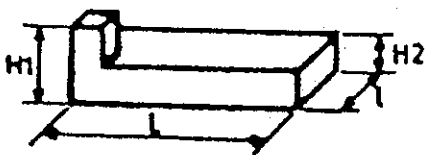

**B 2.3 Tolerable frequency ( $N_C$ ) of lightning to the structure**

**B 2.3.1 General**

The values of  $N_C$  are assessed through the analysis of the damage risk, taking account of suitable factors such as :

- type of construction,
- structure contents,
- structure occupancy,
- lightning stroke consequences.

**B 2.3.2 Determination of  $N_C$**

As indicated above, four determining factors, given by coefficients  $C_2$ ,  $C_3$ ,  $C_4$  and  $C_5$ , are to be assessed using tables B 5 to B 8.

Let  $C = C_2 \cdot C_3 \cdot C_4 \cdot C_5$   $N_C$  is expressed by  $N_C = 5.5 \cdot 10^{-3} / C$

**Table B5**

C <sub>2</sub> , structural coefficient				
Structure	Roof	Metal	Common	Flammable
Metal		0.5	1	2
Common		1	1	2.5
Flammable		2	2.5	3

**Table B6**

C <sub>3</sub> , structure contents	
No value and non flammable	0.5
Standard value or normally flammable	1
High value or particularly flammable	2
Exceptional value, irreplaceable or highly flammable, explosive	3

**Table B7**

C <sub>4</sub> , structure occupancy	
Unoccupied	0.5
Normally occupied	1
Difficult evacuation or risk of panic	3

**Table B8**

C <sub>5</sub> , lightning consequences	
Service continuity not required, and no consequences on the environment	1
Service continuity required and no consequences on the environment	5
Consequences on the environment	10

Note : Specific regulations may impose other values for  $N_C$  in some cases.

### B 3 PROTECTION LEVEL SELECTION METHOD

The tolerable lightning frequency  $N_C$  is compared with the expected lightning frequency  $N_d$ .

The result of this comparison is used to decide whether an LPS is required and, if so, the protection level to be used :

- If  $N_d \leq N_C$ , the LPS is not required systematically.
- If  $N_d > N_C$ , an LPS of effectiveness  $E \geq 1 - N_C/N_d$  should be installed and the associated protection level selected in table B 10.

The LPS design shall meet the specifications given in the standard for the selected protection levels.

When an LPS with an effectiveness factor  $E'$  smaller than the computed factor  $E$  is installed, additional protective measures should be taken. Typical additional protective measures are :

- measures limiting the step or contact voltage,
- measures restricting fire propagation,
- measures reducing the effects of voltage surges induced by lightning on sensitive equipment.

A practical method for selecting the protection level is given in figure B9.

Table B10 gives the critical effectiveness values  $E_C$  corresponding to the limits between the protection levels and the protection levels corresponding to computed effectiveness  $E$ .

**Table B9 - Determination of protection requirement and protection level**

Data input Equations	Computation	Result
Equivalent collector area : $A_e = LW + 6H(L + W) + 9\pi H^2$ (for a rectangular volume)	L = W = H = H <sup>2</sup> =	A <sub>e</sub> =
Expected direct lightning stroke frequency on a structure : $N_d = N_g \text{ max.} \cdot A_e \cdot C_1 \cdot 10^{-6}$	N <sub>g</sub> max = A <sub>e</sub> = C <sub>1</sub> =	N <sub>d</sub> =
Accepted direct lightning stroke frequency on a structure : $N_c = 5.5 \cdot 10^{-3} / C$ where C = C <sub>2</sub> · C <sub>3</sub> · C <sub>4</sub> · C <sub>5</sub>	C <sub>2</sub> = C <sub>3</sub> = C <sub>4</sub> = C <sub>5</sub> = C =	N <sub>c</sub> =
- If N <sub>d</sub> ≤ N <sub>c</sub> : THE PROTECTION IS OPTIONAL. - If N <sub>d</sub> > N <sub>c</sub> : THE PROTECTION IS REQUIRED : . Determine the required protection level by computing the effectiveness $E = 1 - N_c/N_d$ . . Install an ELPI with a protection level corresponding to computed E using table B10 below.		

**Table B10**

Computed effectiveness E	Associated protection level	Peak current I (kA)	Initiation distance D (m)
E > 0/98	Level I + additional measures	-	-
0.95 < E ≤ 0.98	Level I	2.8	20
0.80 < E ≤ 0.95	Level II	9.5	45
0 < E ≤ 0.80	Level III	14.7	60

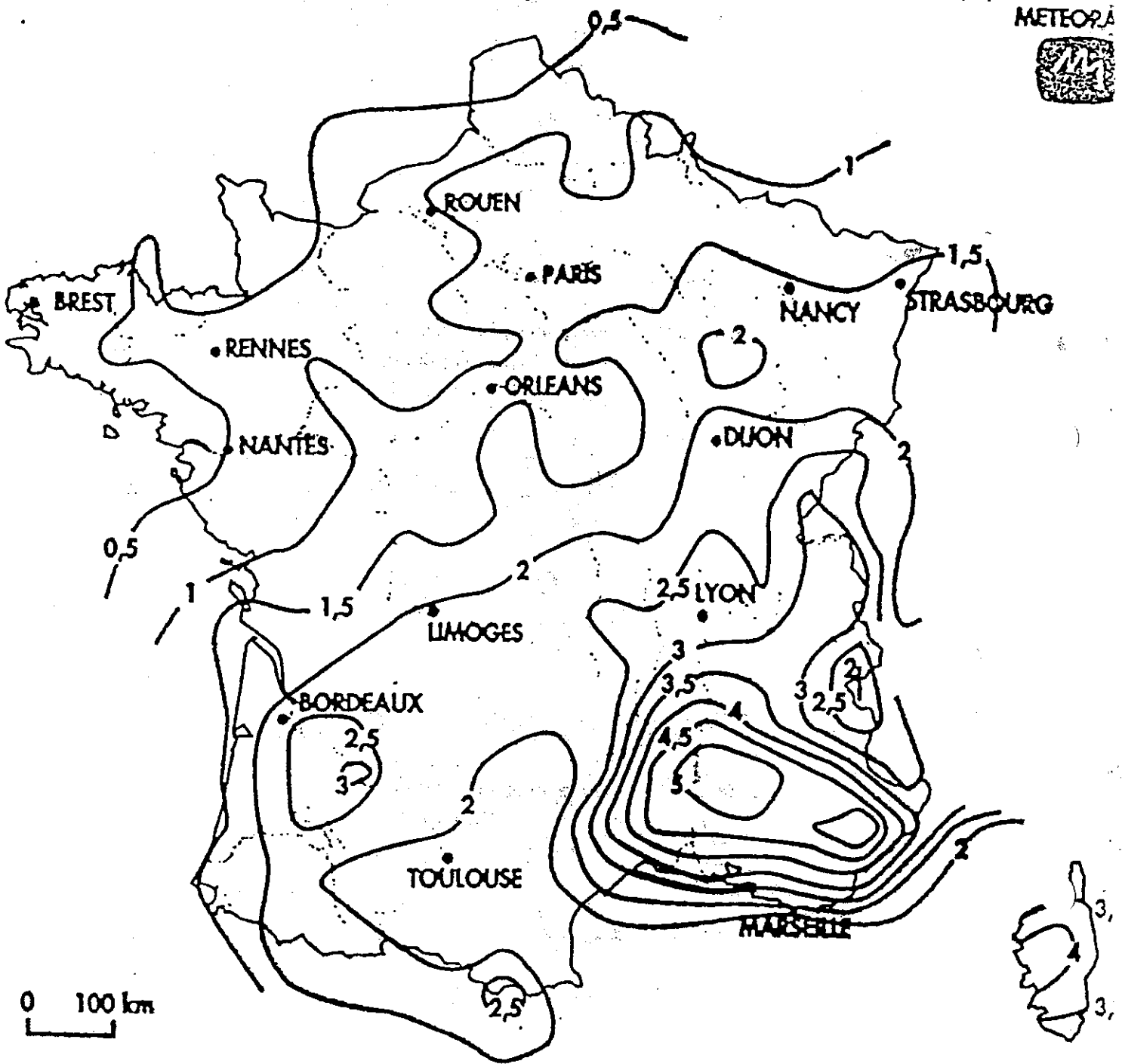

Figure B4 - Map of lightning stroke density  $N_a$  in France

This map is based on statistical data coming from measures collected since 1987 by the national network of lightning detection.

# APPENDIX C

(Normative)

## E.S.E. LIGHTNING CONDUCTOR ASSESSMENT PROCEDURE

### C 1 EXPERIMENTAL CONDITIONS

The effectiveness of an E.S.E. lightning conductor is assessed by comparing the upward leader triggering time emitted by the E.S.E. lightning conductor against the upward leader triggering time emitted by an S.R. lightning conductor.

For this purpose, the SR lightning conductor and E.S.E. lightning conductor are assessed one after the other under the same electrical and geometrical conditions during laboratory tests simulating the natural conditions of the upward leader initiation (positive upward leader).

#### C 1.1 Ground field simulation

The natural ground field existing before a lightning stroke affects the conditions of corona formation and of existing space charges. The natural ground field should therefore be simulated : its value ranges from 10 kV/m to 25 kV/m.

#### C 1.2 Impulse field simulation

To reproduce the natural phenomenon as closely as possible, the ground field build-up is simulated by a waveform the rise time of which ranges from 100  $\mu$ sec to 1000  $\mu$ sec. The waveform slope within the upward leader initiation region should be between  $2 \cdot 10^8$  and  $2 \cdot 10^9$  V/m/s.

### C 2 EXPERIMENTAL SET-UP

#### C 2.1 Positions of lightning protection systems to be compared.

The upper plate/air-termination distance should be sufficient for the upward leader to propagate in free space and, in any case, over a length greater than 1 m ( $d \geq 1$ m). The objects to be compared should be placed in the same electrical environment which is independent of their locations : they should be tested one after the other and centred on ground above the plate and their height should be the same.

#### C 2.2 Dimensions of experimental set-up

The upper plate/ground distance (H) should be greater than 2 m. The ratio  $h/H$  of the air-termination height to the plate height above ground level should range from 0.25 to 0.5. The smaller horizontal dimension of the upper plate is the upper plate/ground H distance.

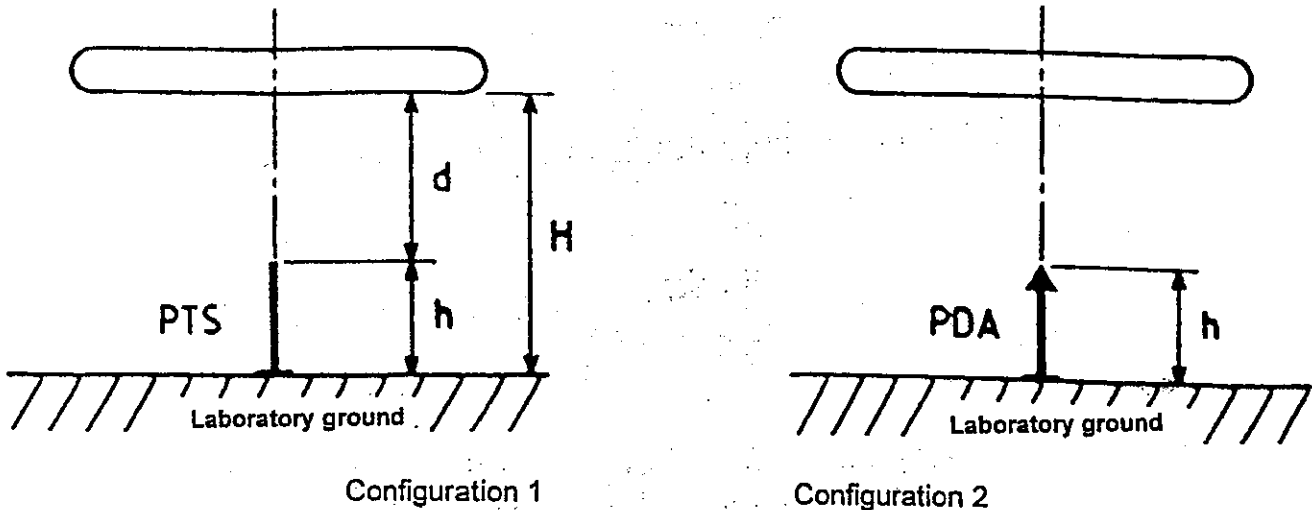

Figure C1

**C 3 PARAMETERS TO BE CHECKED - MEASUREMENTS TO BE TAKEN**

**C 3.1 Electrical parameters**

- Applied voltage waveforms and amplitudes (ambient field calibration, pulsed voltage wave, associated current, etc.);
- Continuous polarisation setting;
- Initiation setting on the reference equipment (simple rod lightning conductor) : initiation probability equal to 1.

**C 3.2 Geometrical conditions**

The distance  $d$  should be strictly the same in each configuration : it should be checked before each test.

**C 3.3 Climatic parameters**

The climatic conditions should be recorded before and after testing in each configuration (pressure, temperature, absolute humidity).

**C 3.4 Number of lightning strokes in each configuration**

The number of lightning strokes should be statistically adequate in each configuration, e.g. about one hundred lightning strokes in each configuration.

**C 3.5 Triggering time**

The criterion adopted for assessing the effectiveness of an E.S.E. lightning conductor is its capacity to initiate an upward leader before an SR lightning conductor under the same conditions. The average upward leader triggering time  $T$  is measured for each usable lightning stroke on the SR lightning conductor and then on the E.S.E. lightning conductor.

## C 4 EFFICIENCY OF THE E.S.E. LIGHTNING CONDUCTOR

### C 4.1 Experimental Assessment of the average triggering times

The upward leader triggering times measured during usable shocks on an SR lightning conductor and an E.S.E. lightning conductor are used to compute the average triggering times  $\overline{T}_{\text{SRLC}}$  and  $\overline{T}_{\text{ESEL C}}$  in compliance with the selected experimental curve parameters.

### C 4.2 Reference waveform

The reference waveform is defined by a rise time  $T_R$  of 650  $\mu\text{sec}$  and a shape as shown in the graph of Figure C2.

Reference waveform

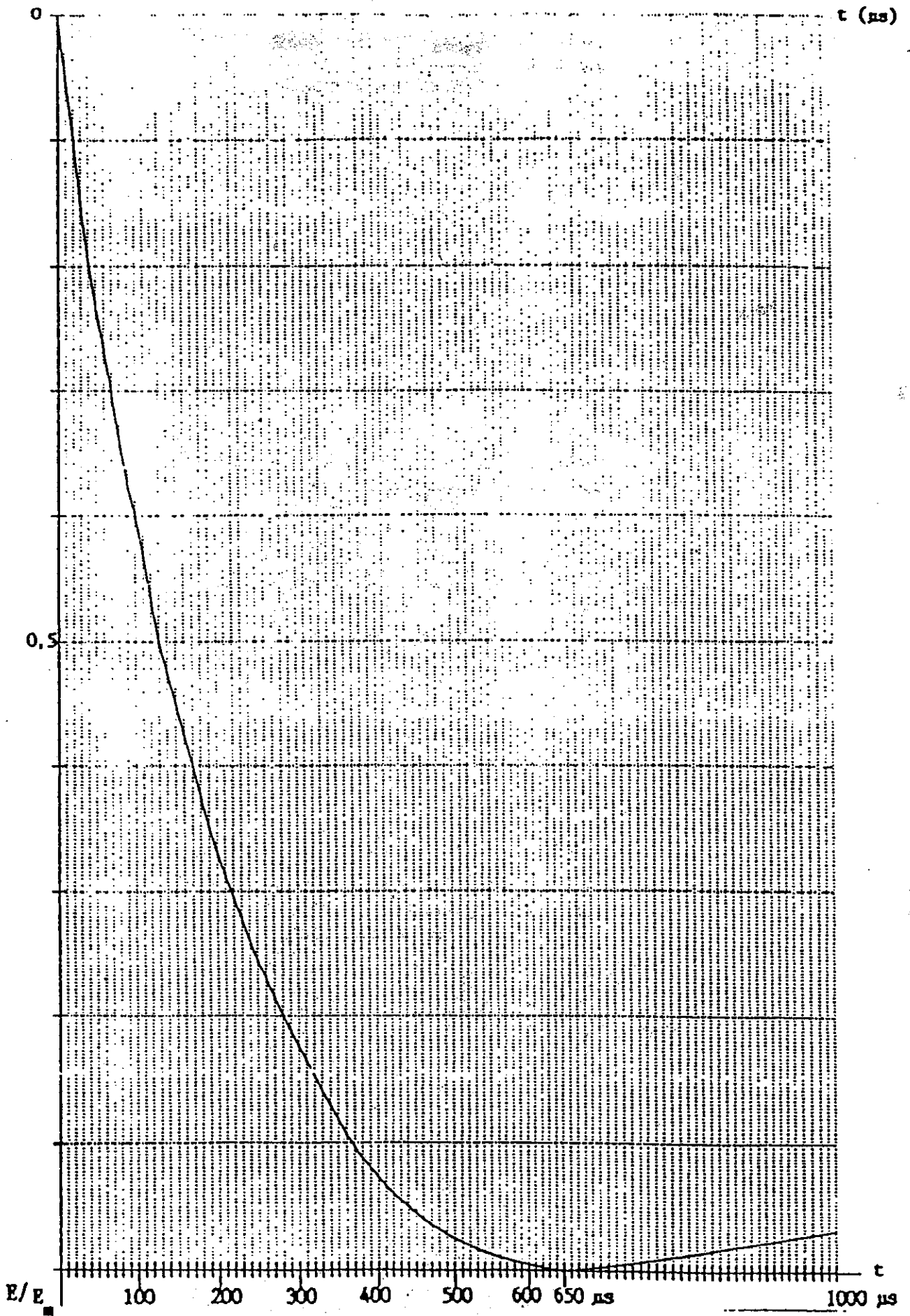

Figure C2

C 4.2 Determination of the triggering advance of the E.S.E. lightning conductor

The experimental curve is plotted on the same graph as the reference waveform to which is assigned the same field value  $E_M$  as the experimental field  $E_{Mexp}$ .

Lines are dropped from  $\overline{T'_{SRLC}}$  and  $\overline{T'_{ESEL C}}$  onto the reference curve and the ordinates of the intersection points give the E field values. The triggering times are obtained by projecting lines from the E values to the points where they intersect the reference curve; the associated values on the x-axis gives the triggering advance  $\Delta T$  ( $\mu\text{sec}$ ) =  $\overline{T'_{SRLC}}$  and  $\overline{T'_{ESEL C}}$ .

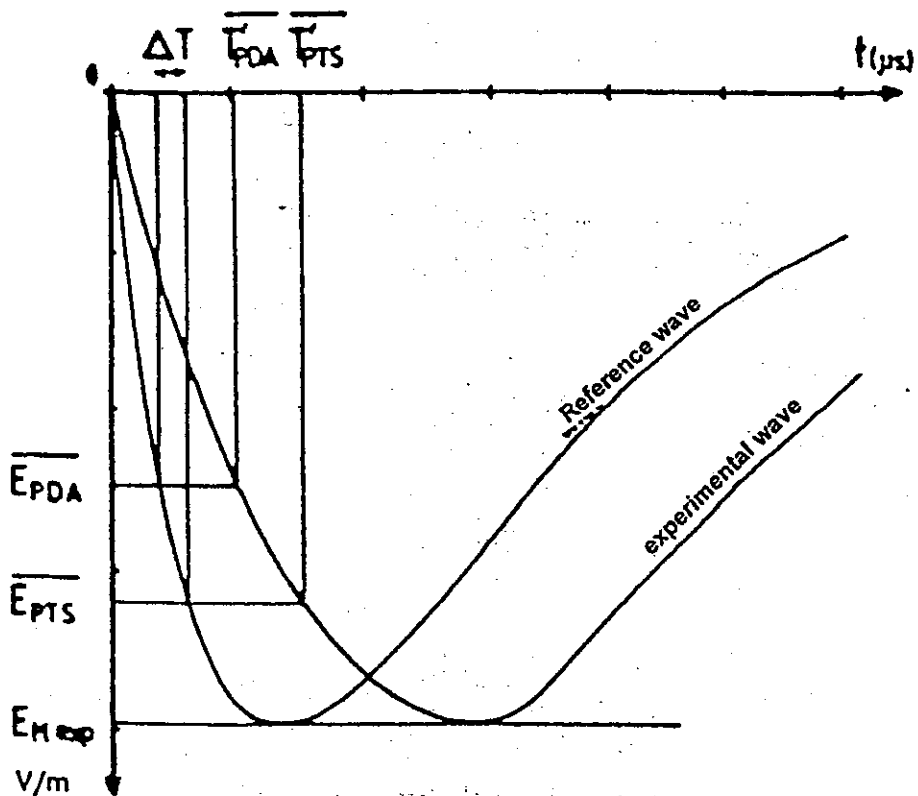

Figure C3

Note : The method proposed above can be used to determine a  $\Delta T$  value in a laboratory. Using the upward leader initiation fields which only depend on air-termination height  $h$ , a  $\Delta T$  value independent of  $d$  can be determined. This transposition is accomplished using the continuous leader starting threshold field model developed by Rizk & Berger.

# APPENDIX D

(Informative)

## TYPICAL LIGHTNING PARAMETERS AND ASSOCIATED EFFECTS

### D 1 TYPICAL LIGHTNING PARAMETERS

#### D 1.1 Impulse component waveforms (discharges) of a lightning stroke

Figure D1 shows a few lightning current waveforms. Such lightning currents have been recorded at the San Salvatore Mount research station in Switzerland. Tables D3 to D15 show the cumulated frequency distributions of the lightning characteristics.

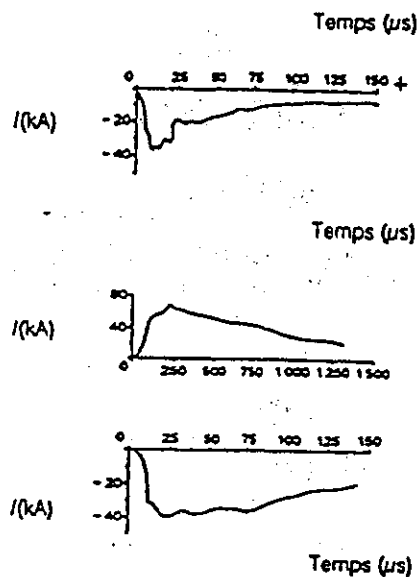

Negative and positive lightning currents measured on San Salvatore Mount at Lugano (Switzerland)

Figure D1 - Examples of lightning currents

#### D 1.2 Distribution of the different lightning parameters

A considerable number of parameters are used to describe the lightning impulse (or impulses in case of negative lightning), including in particular : current amplitude, rise time, decay time, charge and specific energy.

These parameters refer to the actual lightning stroke waveforms as measured to compute the distribution statistics. Initially, the amplitude, decay time and rise time may be considered as defined as in a laboratory. The charge corresponds to  $\int idt$  and the specific energy to  $\int i^2 dt$ . The usefulness of these parameters is explained below.

The steepness (steepest current slope in  $kA/\mu sec$ ) is also sometimes a useful data for characterising an impulse though it is related to other parameters already defined : rise time and amplitude.

The total lightning flash, including the impulse(s) and the following current flowing in the interval between two impulses is essentially characterised by its total duration.

## D 2 THERMAL EFFECTS OF LIGHTNING PARAMETERS

The parameters mentioned in the foregoing do not generally have the same effects or failure modes as regards the different types of equipment.

The current amplitude is useful for addressing the voltage surge problems and mechanical load problems generated by lightning.

The rise time is only used to address the voltage surge problems.

The decay time is related to mechanical loads in that it is used to determine the electromagnetic force application time; it is mainly representative of the lightning stroke energy in connection with the amplitude. To represent this energy, the amplitude/decay time binomial can be replaced by :

- Specific energy  $\int i^2 dt$  (amplitude and decay time) when the LPS component dimensions are considered (connectors, conductors, etc.);
- Charge  $\int i dt$  (amplitude and decay time) in the case of the characteristics of surge protective devices connected to lightning protection systems (E.S.E. lightning conductor + earth-termination system) or metal melting at the lightning strike point.

### D 2.1 Thermal effects related to charge quantity Q

Thermal effects are observed in lightning protection installations especially when the air-termination systems have sharp tips on which melting is sometimes observed over a maximum of a few millimetres. In the case of flat surfaces (sheet-metal plates), evidence of melting is found which may result in complete piercing.

An exceptional lightning stroke (300 C) is capable of piercing sheet-metal plates of up to 2-3mm thick.

This accounts for the minimum thickness requirement when a metal plate is used or likely to serve as a lightning collector (e.g., 4 mm for iron, 5 mm for copper).

Low-intensity discharges with a long duration may readily cause ignition. As lightning discharges are usually accompanied by a continuing current, lightning strokes are seldom cold. Even dry wood can be ignited by this kind of lightning with long-lasting continuing currents.

Poor contacts are particularly dangerous points along the lightning current path. Contact resistance values of a few thousandths of an ohm already generate enough heat to melt appreciable quantities of metal producing sparks. When a readily flammable material is located near such poor contact points, indirection ignition may result. This kind of sparking is particularly dangerous in premises exposed to a risk of explosions and in explosive manufacturing plants.

## D 2.2 Thermal effects related to current integral $\int i^2 dt$

When the lightning current enters a metal conductor in which it can propagate, the resulting heat dissipation obeys the Joule's law which involves the square of the current  $i^2$ , current flowing time  $t$  and ohmic resistance  $R$ .

Significant thermal effects are therefore encountered especially at high-resistance points.

The direct-current resistance measured on a conductor should not however be taken as the resistance value  $R$ . Lightning currents are short shock waves which produce a skin effect as in the case of high-frequency currents, i.e., the current flow is confined to a thin conductor surface layer a few tenths of a millimetre thick, as measured in direct current, which corresponds to the total cross-sectional area.

There are no visible consequences of this heating, in spite of the skin effect, when the conductor gauge is large enough. Temperature rises up to the melting point temperature only occur in conductors having a small gauge or high resistivity. Melting effects are often observed, for instance, in antenna cables and wires. On the other hand, cases of melting are seldom observed on larger gauge wires of a few millimetres in diameter (such a barbed wires). Melting has never been seen in lightning conductors having the gauge recommended in this standard.

On the other hand, the current flow in poor conductors releases a large amount of energy in the form of heat. This is why the water contained in wood, concrete and similar materials is heated up and vaporised. The entire phenomenon lasts a very short time and, as a consequence of the subsequent pressure rise, trees, wooden masts, beams and walls burst. Explosive effects of this kind more particularly occur in places where moisture has accumulated (slits, vessels full of sap) or the current density has risen significantly, i.e., at the points of current entry or exit between a material having a poor conductivity (cement) and a material having a high conductivity (attaching clamps of a damaged lightning down-conductor, electrical conduit cramps, water and gas pipe steel clamps).

## D 2.3 Electrodynamic effects

Significant mechanical loads may occur only when sections of the lightning current path are laid out one relative to the other in such a way that one of them is located within the magnetic field generated by the other. In this case, the load increase is inversely proportional to the distance between these sections. Small turns are subjected to considerable enlarging loads. Considering a 10 cm diameter ring made of 8 mm diameter wire, a very heavy lightning current of 100 kA will apply a force of 1200N to each centimetre of the periphery. With a 2m diameter, the force would drop to 140N. Due to the reciprocal interaction between the lightning current in a conductor and the Earth's magnetic field, mechanical effects of only about 10N per metre of conductor can be produced; such effects are trivial.

In addition to these repulsion forces, which may distort conductors in rare cases, there are also strong attraction forces between parallel lightning current paths when they are quite close. In this way, thin tubular antennae are crushed and parallel conductors knock together.

#### D 2.4 Potential differences and arcing

The surprising profusion of spark traces observed after a violent lightning stroke, sometimes even in buildings provided with lightning protection systems, can be explained by two effects well known in electrical engineering : the earth-termination potential rise, which mainly depends on the peak intensity (amplitude) of the drained current, and the induction phenomena which mainly depend on the  $di/dt$  gradient (leading edge steepness) of this current.

##### D 2.4.1 Earth-termination potential rise

Due to the earth-termination resistance  $R$ , resulting from the resistivity of the soil itself, there is a potential difference between the LPS down-conductor and nearby points while the current is flowing. The total potential rise relative to the unaffected remote ground (therefore remaining at the conventional zero potential) is expressed by Ohm's law :  $U = RI$

A 100 kA current flow through a 5-ohm earth-termination system will cause a potential rise in the lightning current draining system of 500 kV relative to remote ground points.

Such a potential rise is actually distributed in the ground according to a law which depends on the type of earth-termination system and the soil characteristics.

All the conductive parts of the structure which are connected to the earth in any way (heating systems, pipe lines, electrical systems, cable armours) are also subjected to a potential rise if they are not interconnected. The only way to prevent insulation breakdown is to provide an electrical connection through down-conductors to independently earthed parts. In this way, these become integral parts of the lightning protection system and can therefore drain part of the lightning current according to branch circuit laws. Their connection to the down-conductors make them an integral part of the LPS.

As no conductive connections to live electrical lines can be made, this standard recommends the installation of voltage surge protective devices known as lightning arresters (varistors or spark gaps). However, these lightning arresters should then be sized to withstand a non-negligible portion (from a few per cent up to 50 per cent, approximately, in the worst case) of the lightning current striking the LPS.

Note : Given the frequencies involved in lightning phenomena, the earth-termination system impedance should be taken into account in addition to the measured earth-termination system direct-current resistance.

## D 2.4.2 Induction phenomena

Shorter distance between down-conductor and metal building structures

An LPS down-conductor forms open loops with the various metal structures of a building (water pipes, central heating system, electrical power lines, etc.). These loops will be subjected to induction phenomena and electromotive forces will appear between their open ends. This standard allows for this phenomena in article 3.

### TABLES D2 TO D14

These tables are extracted from IEC 1024-1, Part 1, Section 1, Guide A, "Selection of protection levels for lightning protection systems"

#### Basic values of lightning current parameters Cumulative frequency distribution

Table D2 - Peak current (kA) (min 2 kA)

Lightning stroke	Cumulative frequency				
	98 %	95 %	80 %	50 %	5 %
First negative strokes	4		20		90
Subsequent negative strokes		4.6		12	30
Positive flashes		4.6		35	250

Table D3 - Total charge (C)

Lightning stroke	Cumulative frequency		
	95 %	50 %	5 %
First negative strokes	1.1	5.2	24
Subsequent negative strokes	0.2	1.4	11
Negative flashes	1.3	7.5	40
Positive flashes	20	80	350

Table D4 - Impulse charge (C)

Lightning stroke	Cumulative frequency		
	95 %	50 %	5 %
First negative strokes	1.1	4.5	20
Subsequent negative strokes	0.22	0.95	4
Positive flashes	2	16	150

Table D5 - Front time duration ( $\mu$ s)

First negative strokes	Cumulative frequency		
	95 %	50 %	5 %
Total rise time	1.8	5.5	18
Rise time between :			
30 % and 90 % of peak current	1.5	3.8	10
10 % and 90 % of peak current	2.2	5.6	14

Table D6

Subsequent lightning strokes	Cumulative frequency		
	95 %	50 %	5 %
Total rise time	0.2	1.1	4.5
Rise time between :			
30 % and 90 % of peak current	0.1	0.6	3.0
10 % and 90 % of peak current	0.2	0.8	3.5

Table D7

Positive flashes	Cumulative frequency		
	95 %	50 %	5 %
Total rise time	3.5	22	200

Table D8 - Stroke duration ( $\mu\text{s}$ )

Lightning stroke	Cumulative frequency		
	95 %	50 %	5 %
First negative strokes	30	75	200
Subsequent negative strokes	6.5	32	140
Positive flashes	25	200	2000

Table D9 - Specific energy ( $\text{J}/\Omega$ )

Lightning stroke	Cumulative frequency		
	95 %	50 %	5 %
First negative strokes	$6.0 \times 10^2$	$5.5 \times 10^4$	$5.5 \times 10^5$
Subsequent negative strokes	$5.5 \times 10^2$	$6.0 \times 10^3$	$5.2 \times 10^4$
Positive flashes	$2.5 \times 10^4$	$6.5 \times 10^5$	$1.5 \times 10^7$

Table D10 - Rate of rise ( $\text{kA}/\mu\text{s}$ )

First negative strokes	Cumulative frequency		
	95 %	50 %	5 %
Maximum rate of rise	9.1	24	65
Average steepness between :			
30 % and 90 % of peak current	2.6	7.2	20
10 % and 90 % of peak current	1.7	5	14

Table D11

Subsequent negative strokes	Cumulative frequency		
	95 %	50 %	5 %
Maximum rate of rise	10	40	162
Average steepness between :			
30 % and 90 % of peak current	4.1	20	99
10 % and 90 % of peak current	3.3	15	72

**Table D12**

Positive flashes	Cumulative frequency		
	95 %	50 %	5 %
Maximum rate of rise	0.2	2.4	32

**Table D13 - Total flash duration (ms)**

Lightning stroke	Cumulative frequency		
	95 %	50 %	5 %
All negative flashes	0.15	13	1100
Subsequent negative strokes	31	180	900
Positive flashes	14	85	500

**Table D14 - Time intervals between strokes (ms)**

Lightning stroke	Cumulative frequency		
	95 %	50 %	5 %
Multiple negative strokes	7	33	150

# APPENDIX E

(Informative)

## PROTECTING PEOPLE AGAINST ELECTRICAL SHOCKS

### E 1 GENERAL

People standing outdoors run the greatest risk of being struck by lightning, whether directly or caused by the step voltage. For people inside a structure, the hazards are due to :

- (a) the abrupt potential rise in items connected to lines leading from the outside such as power lines, telephone lines, outdoor TV antenna cables;
- (b) metal objects within the structure which may also be brought to high potentials : contact voltage.

The measures stated in this standard to prevent dangerous sparking are designed to reduce the risks run by people inside structures.

### E 2 PERSONAL BEHAVIOUR

To protect themselves against lightning, individuals should take the following minimum precautions :

- (a) look for a shelter in a place covered by an earthed roof or an all-metal shelter,

Note : Conventionally manufactured tents do not provide protection.

- (b) when there is no shelter nearby, reduce one's height (crouch down) and surface area on the ground (join the two feet) and do not touch any earthed object with the hands,
- (c) do not ride a bicycle or a horse. Do not remain in an open-top car,
- (d) do not walk or swim in water,
- (e) keep away from high places, or tall or isolated trees. If the vicinity of a tree cannot be avoided, stand beyond the foliage limits,
- (f) do not touch or stand next to metal structures, metal fences, etc.,
- (g) do not carry any object which extends above the head (umbrella, golf club, tool, etc.),
- (h) do not use or minimise the use of cord telephones,
- (i) do not touch any metal object, electrical appliances, window frames, radio sets, TV sets, etc.

**E 3**

**FIRST AID**

The first aid to be given is the same as in the case of electric shocks or burns. Artificial respiration should be administered immediately by a first-aid worker. Such action and other emergency first-aid may save the injured person.